



*The Fireplace
Collection*



PROFILE SAW IN ACTION



MARBLE CUTTING AND PROFILING MACHINES



CORNICE SHELF BEING HAND CARVED



- *About us...*

We are an expert fireplace company whose aim is to supply high quality products through our trade partners. Our products are made in our workshops in Kent. Please contact your local retailer for all your fireplace needs as we do not serve the general public.

- *What we offer...*

We have a wide range of traditional & contemporary products and examples can be found in this brochure. We only use natural materials quarried in Europe & Asia. All our fireplaces are hand made and as such a tolerance of up to 5mm should be allowed for all measurements.

- *Bespoke service...*

We are also happy to quote for any bespoke commissions. We often work from drawings, photos etc. in any natural material.

- *Restoration...*

We also specialize in high quality restoration of antique stone and marble fireplace surrounds. Please see examples of our restoration work on the next few pages.

Contents

Antique Restoration

Restoration examples 05-07

Reproduction range

Georgian 10-15

Regency 16-29

Victorian 30-39

Contemporary 40-65

Hole in the wall 66-75

Guide to materials 76

Guide to dimensions 77

Antique Restoration

An old trade client a friend of 15 years arrives. Fresh cup of coffee first then the back door of his van opens and the restorer's face lights up with excitement. Yet another chimney piece once carved with so much care and expertise. It takes only seconds for the hawk eyes to scan all the components as if trying to soak up all the skill an effort which must have gone into making this masterpiece. The air is filled with the smell of soot from all the open fires of the last two centuries. Carvers like those of the past just do not exist anymore. They had all the time and passion in the world. We mostly rush around. How beautifully executed with delicate and life like quality of carved leaves and figures. You'd think it is impossible to carve something like this. Only a few can really appreciate the work. The restorer does. He tried to match the quality where pieces were missing many times before....

Just where can we go and get the same completely white piece of Italian Statuary marble? It just isn't there anymore.

All the pieces will now be laid out on the floor. All missing and damaged components will be discussed. Once we understand the level of restoration our client requires the work can start. Each component is cleaned and repair before all is assembled using traditional techniques with the help of modern equipment.

It is such a pleasure to be able to proudly admire the final result. Seeing the piece restored to its former glory is a feeling which makes this job one of the best there is!

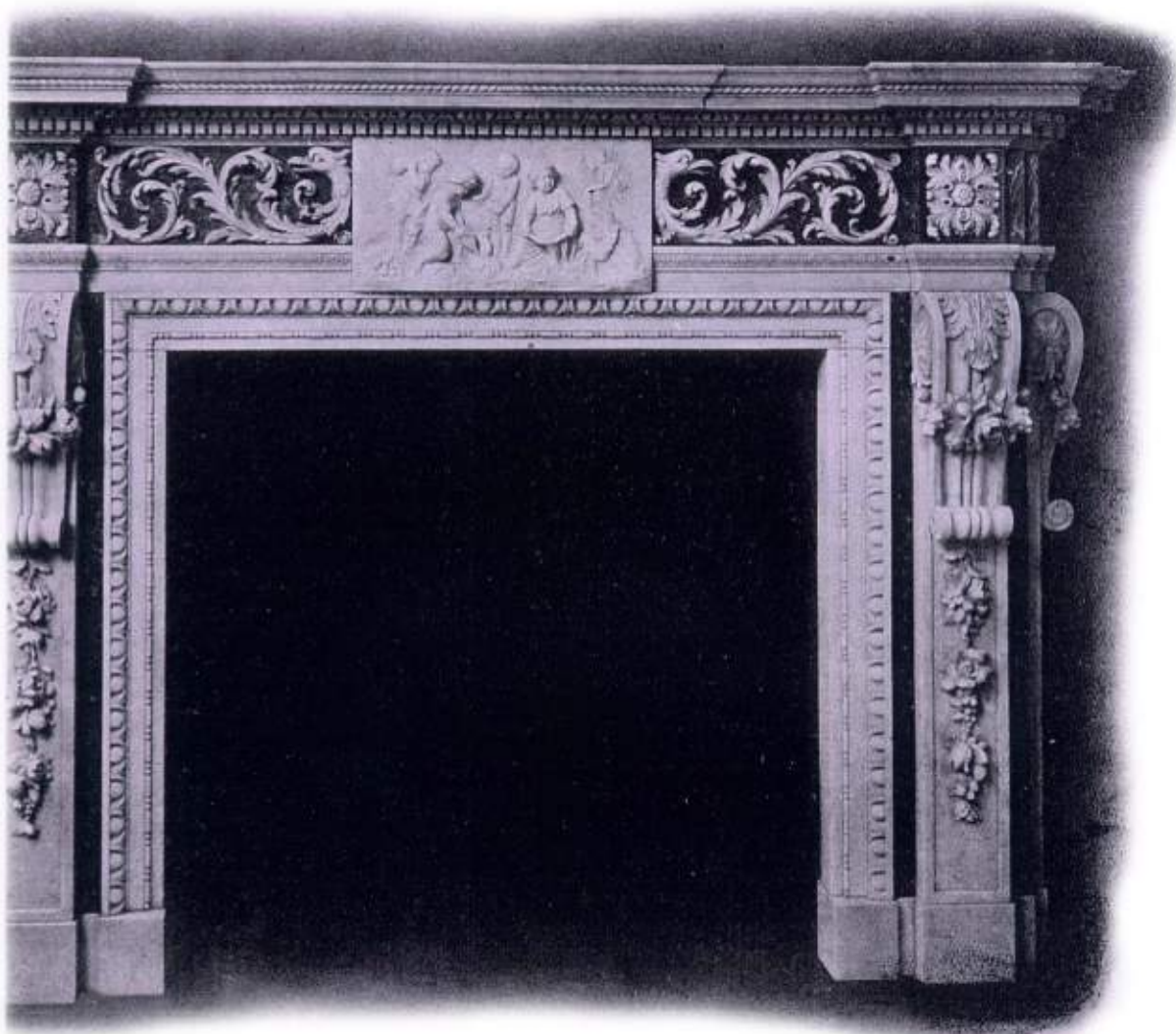

EXAMPLES OF FIREPLACES RECEIVED IN OUR WORKSHOP FOR RESTORATION



PAINTED FIREPLACE PARTS AS FOUND IN SITU



LOVINGLY RESTORED TO ITS FORMER GLORY WITH EVERY COMPONENT REPOLISHED AND REASSAMBLLED TO ITS ORIGINAL CONDITION WITH A LIGHT WAXED FINISH



CAST IRON COMBINATION FIREPLACES BEFORE AND AFTER RESTORATION.



SPECTACULAR CHIMNEYPIECE THOUGHT TO HAVE BEEN BEYOND REPAIR DUE TO HIGH DEGREE OF MARBLE CALCIFICATION.

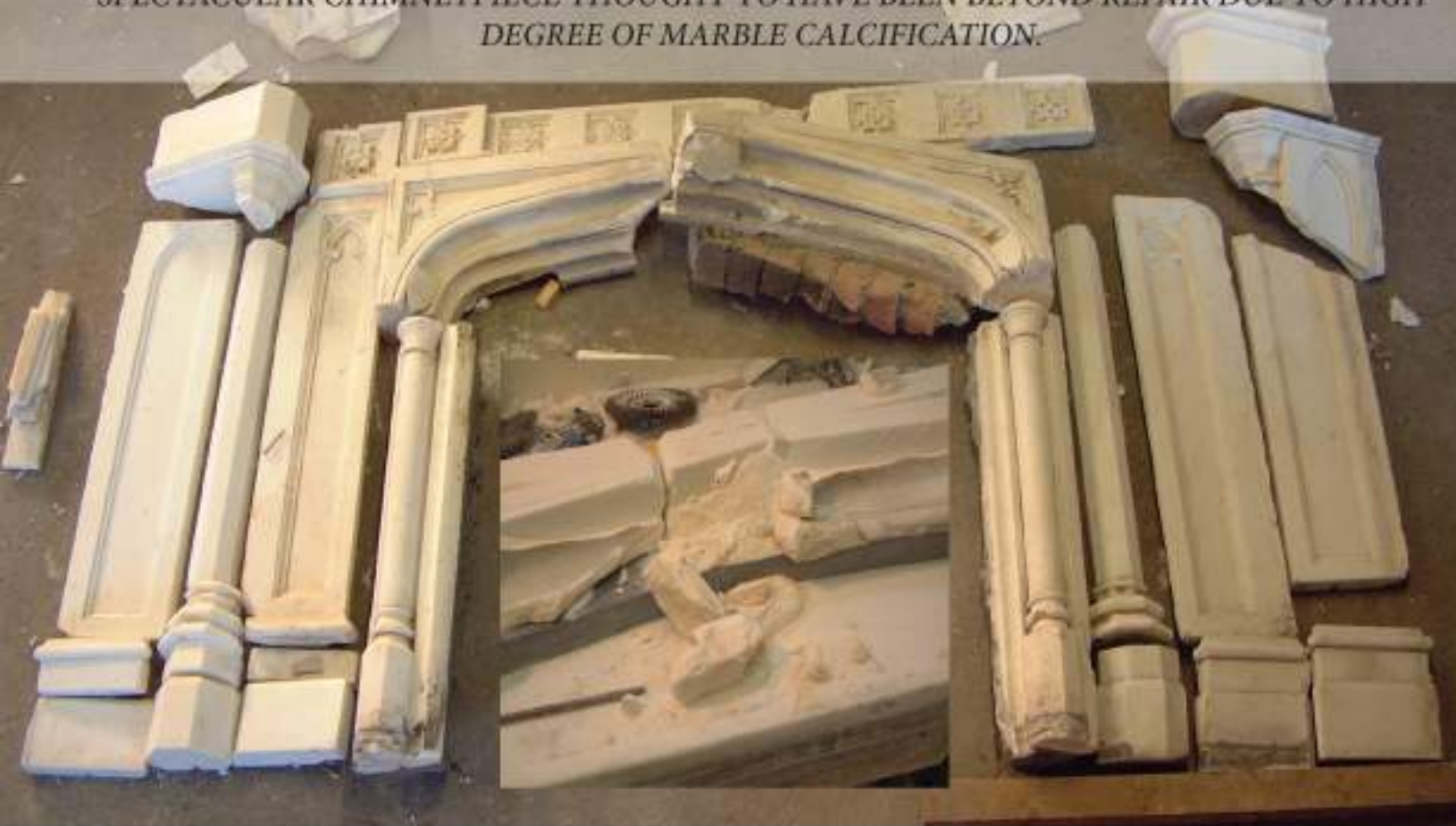

FIREPLACES READY FOR DELIVERY AS WELL AS ITEMS AWAITING RESTORATION.



Reproduction range

We are proud to be one of a handful of companies still passionate about manufacturing fireplaces in England. Our workshop is said to be one of the best laid out and organized in the country. The water for our profile saws is recycled through a simple yet efficient cascading water system and used time and time again. We even use the rain water to minimize our impact on the environment. All members of staff form a strong family like team whose understanding of carrying each task well is crucial for the end result. The success of the final product starts with material selection which is then cut and profiled by an incredibly strong and multitasking sawyer. Once dry, all stone moves through the workshop to the assembly benches. All products are then checked for uniformity, washed and sealed ready for clients' delivery.





Adam

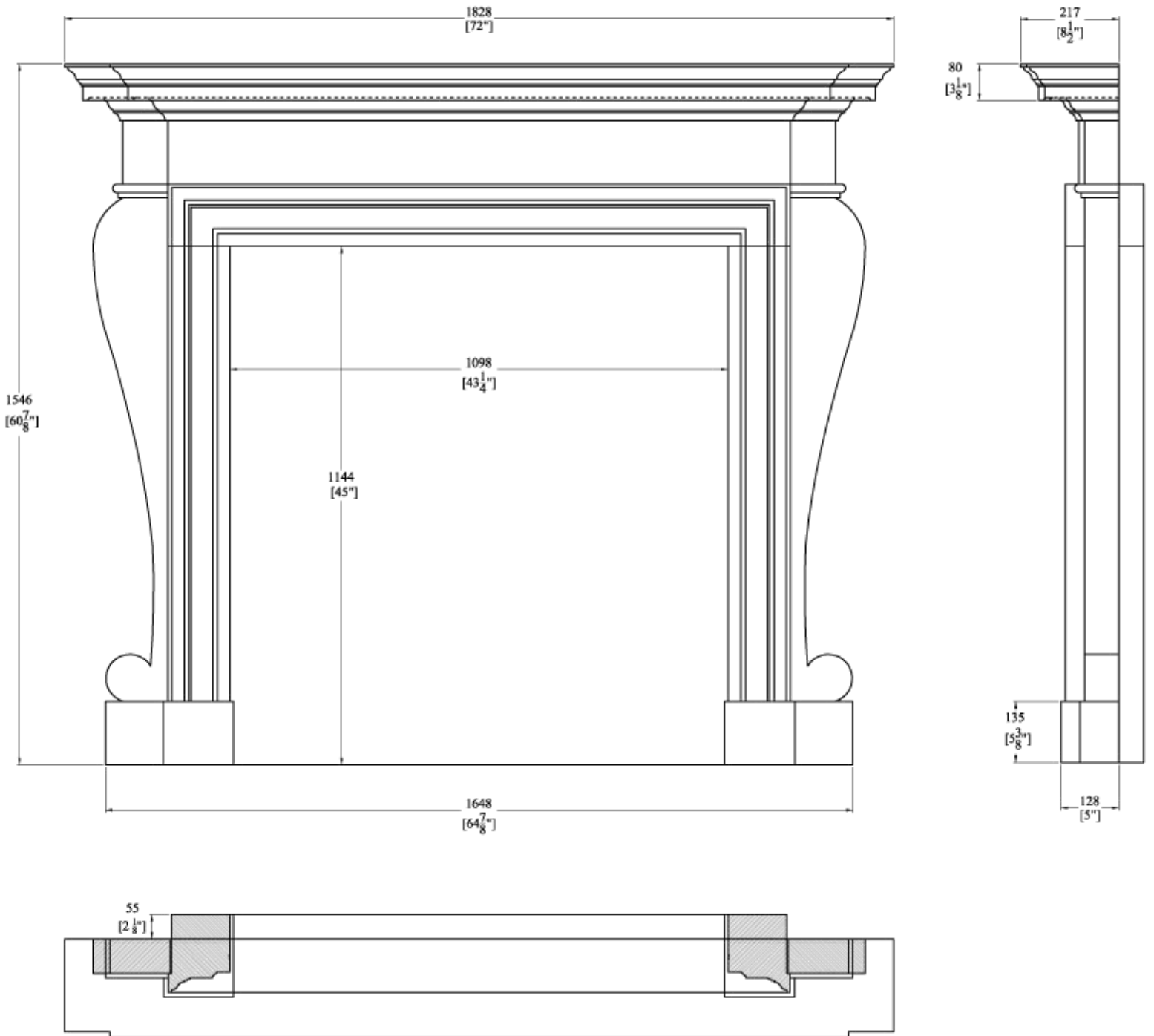



Georgian Bolection

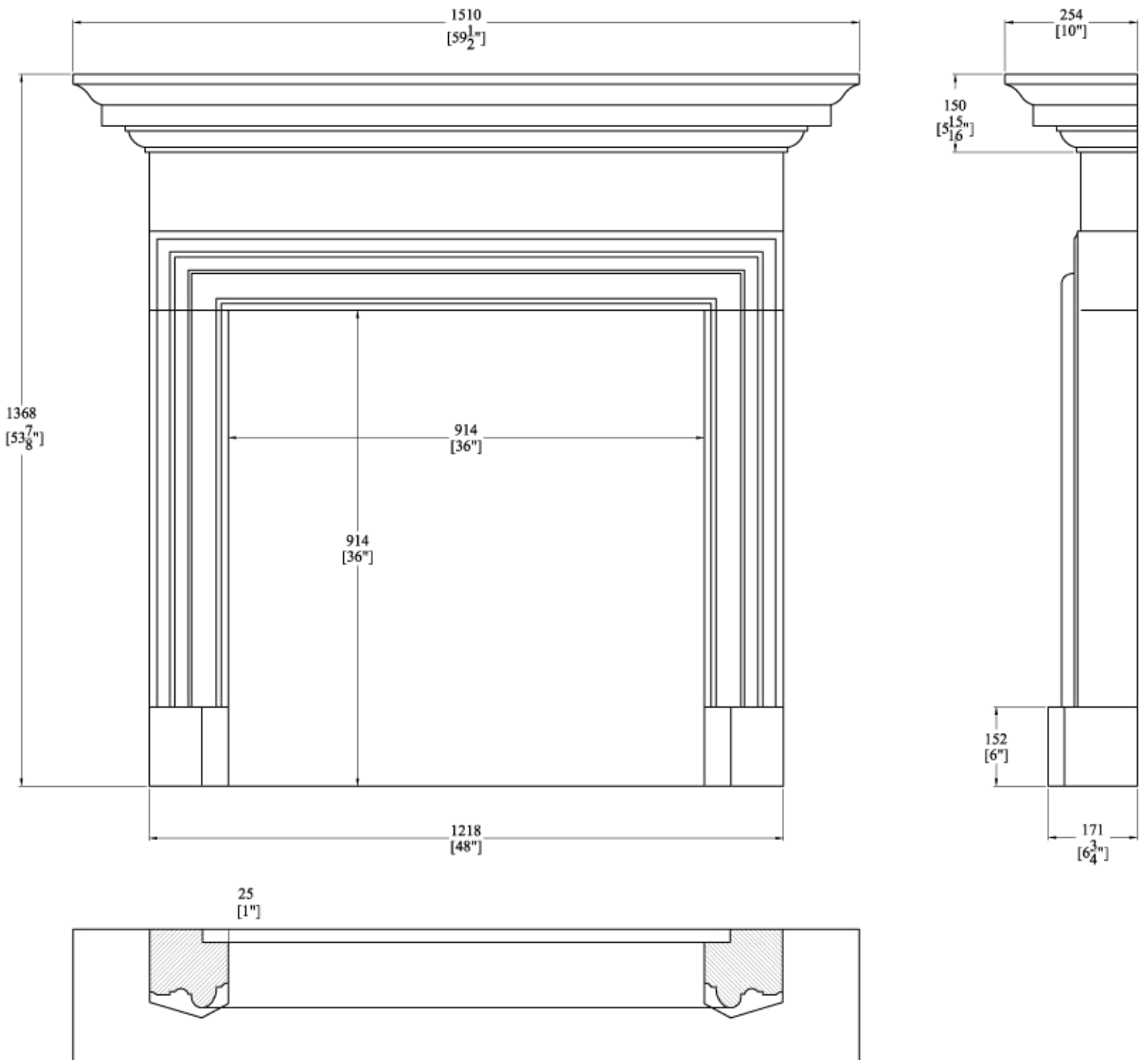



Bolection

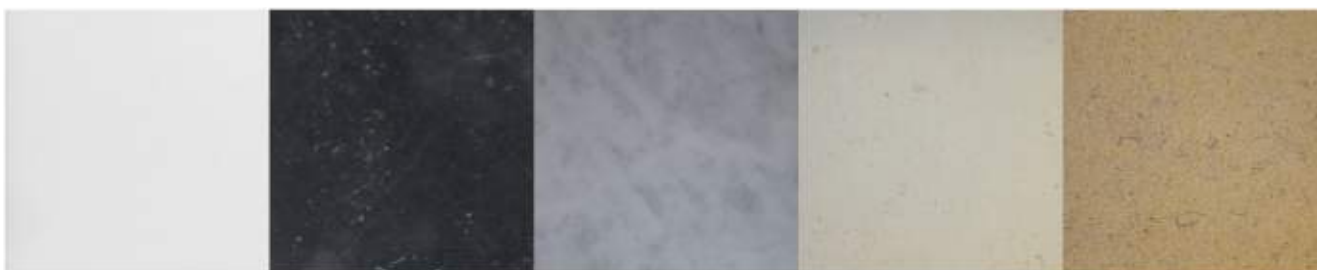
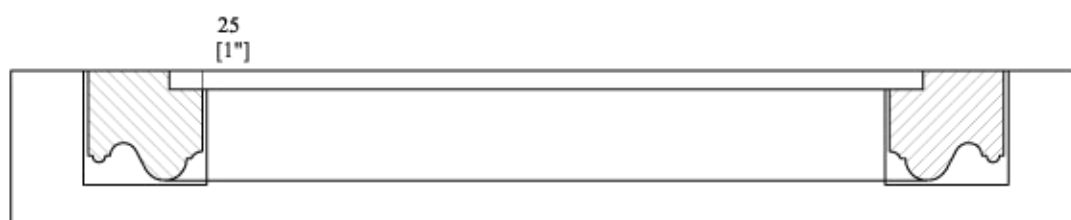
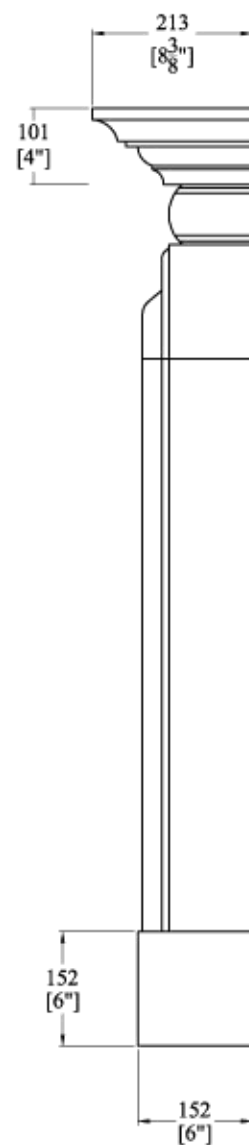
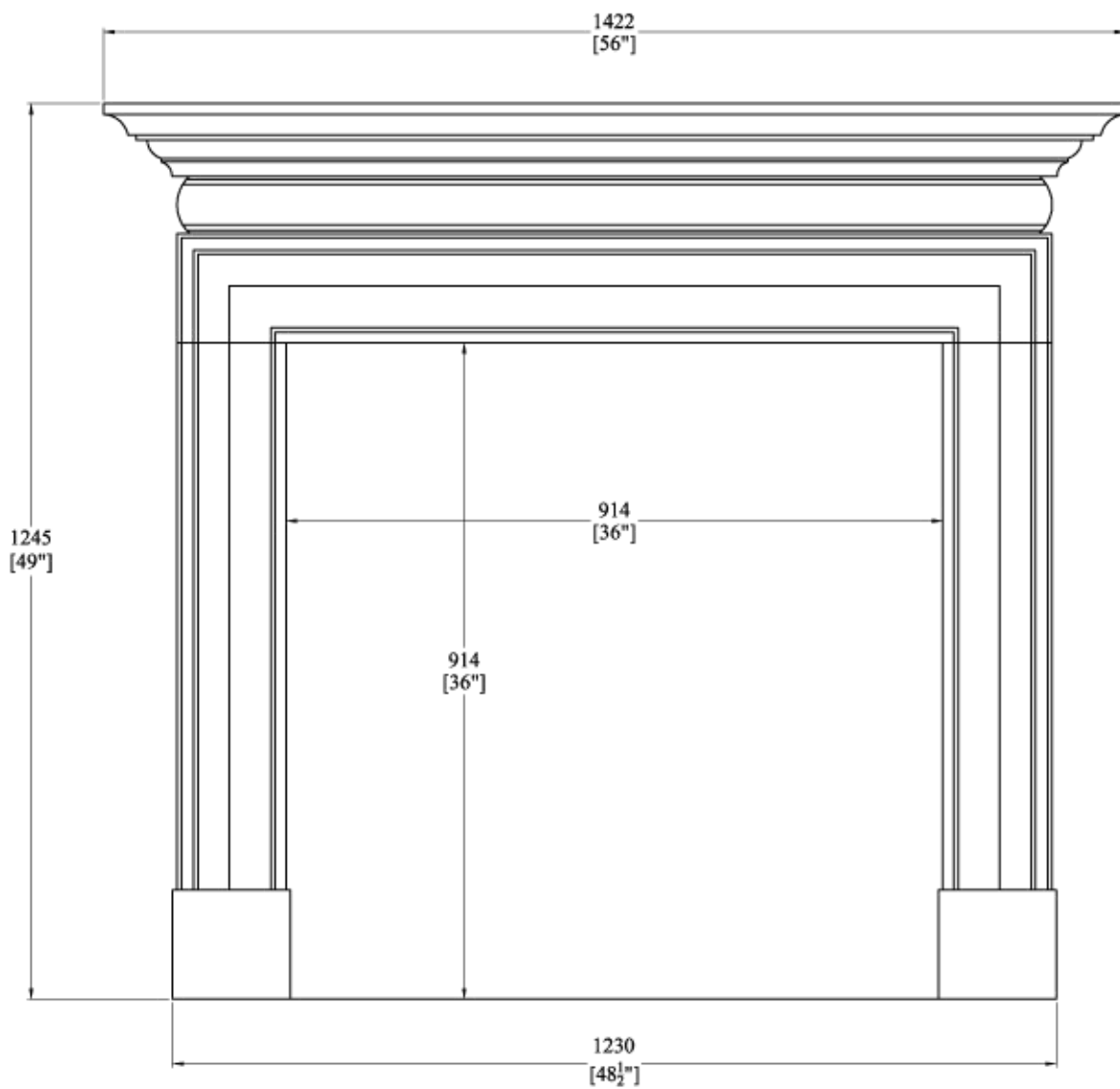



Acanthus Leaf

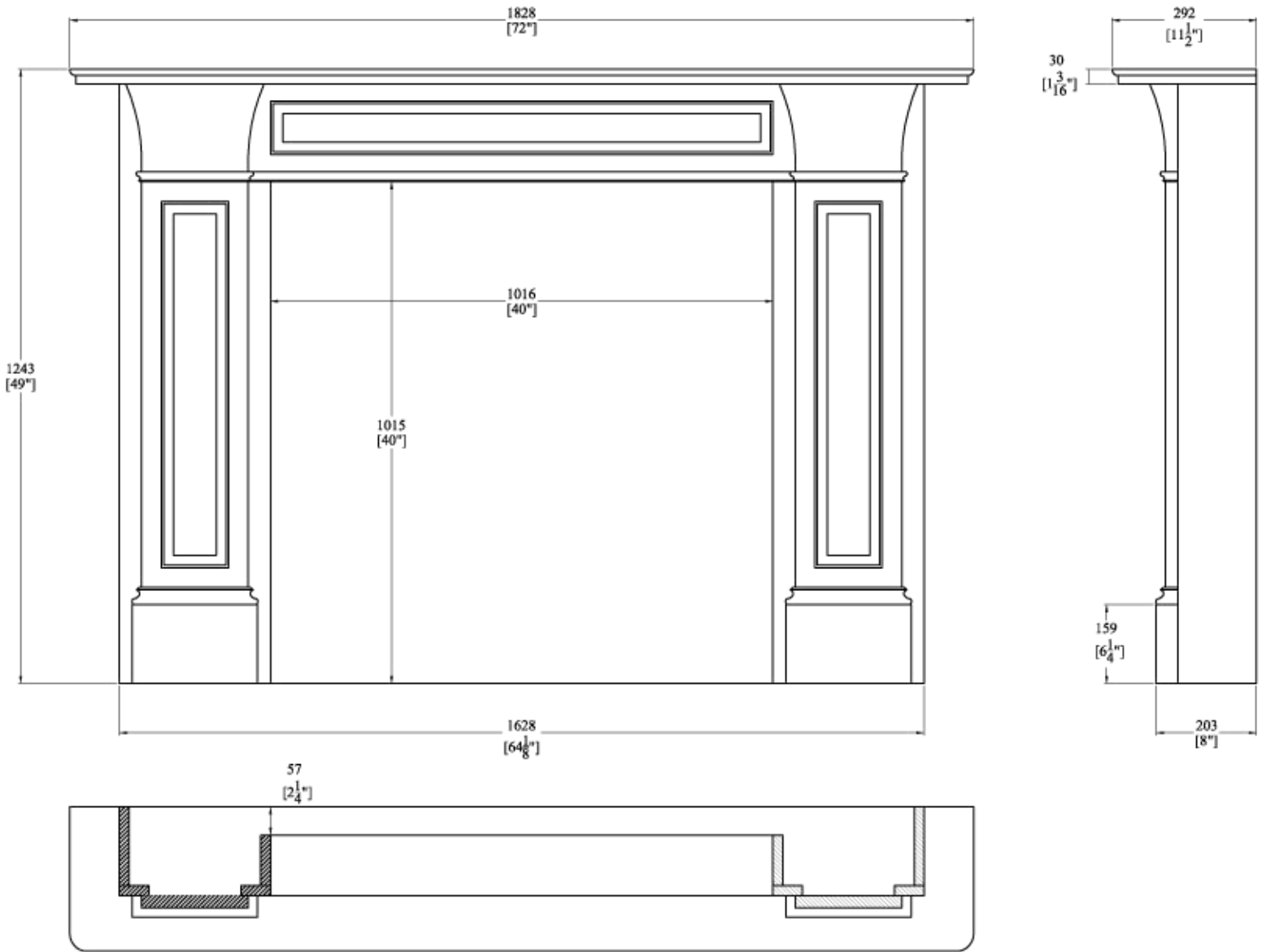



Brunel

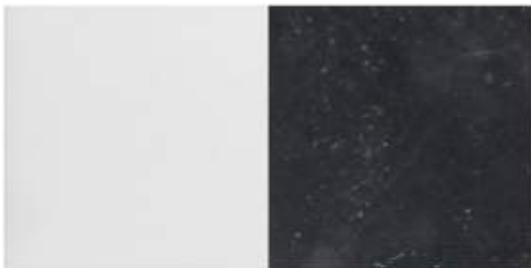
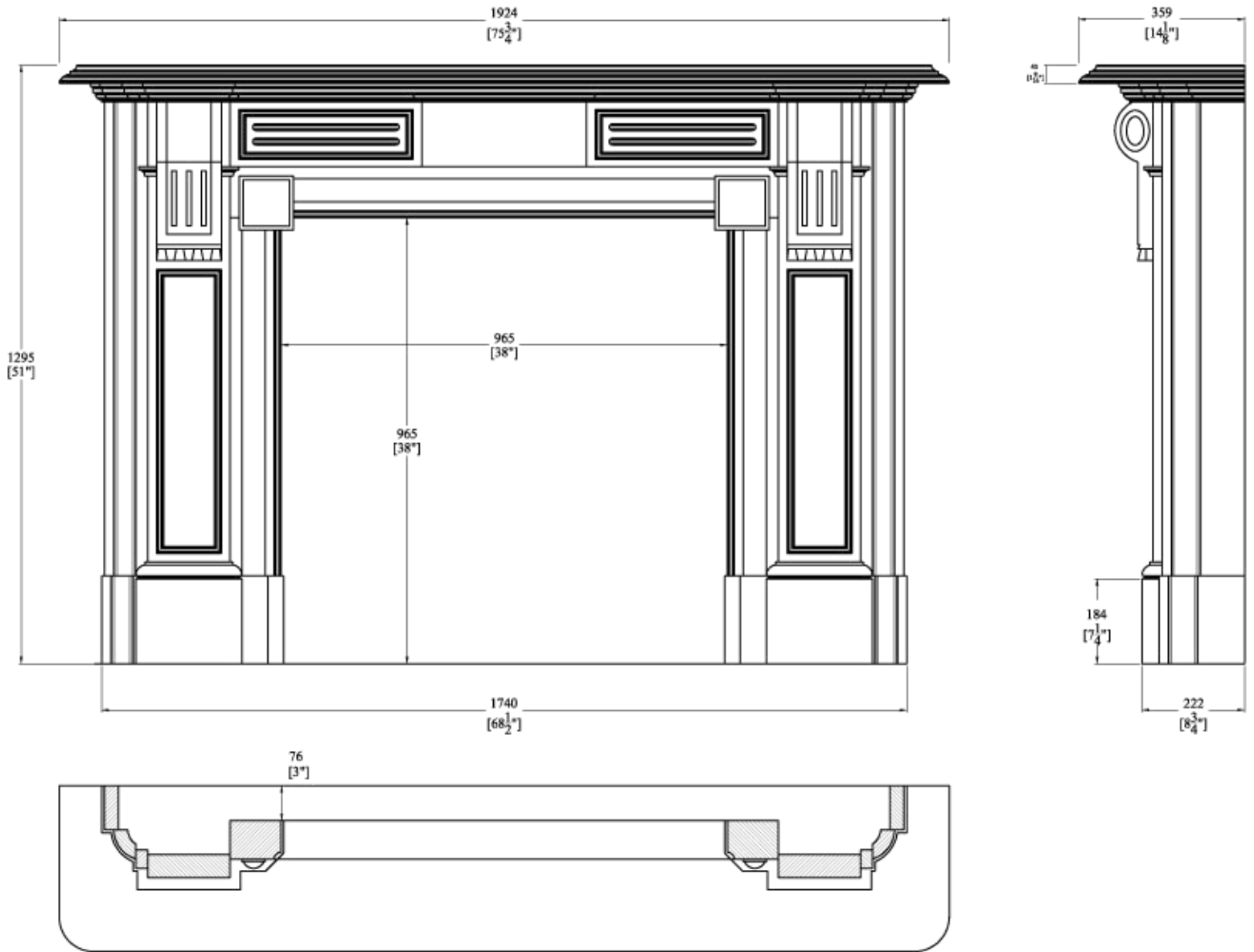

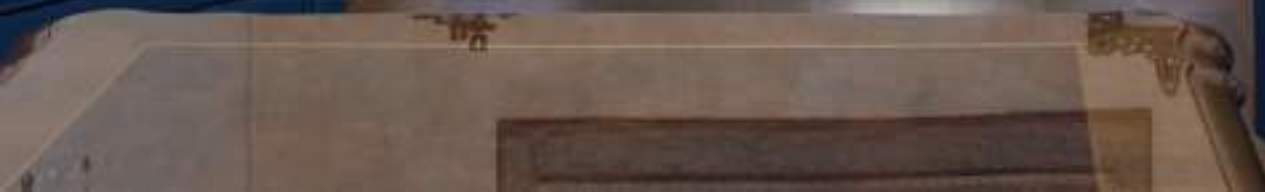

Duchess

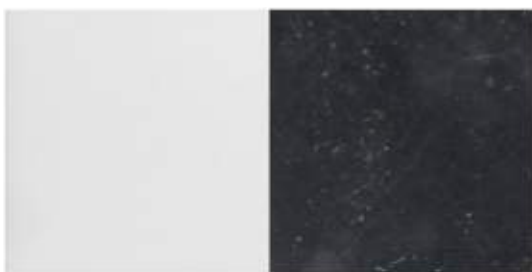
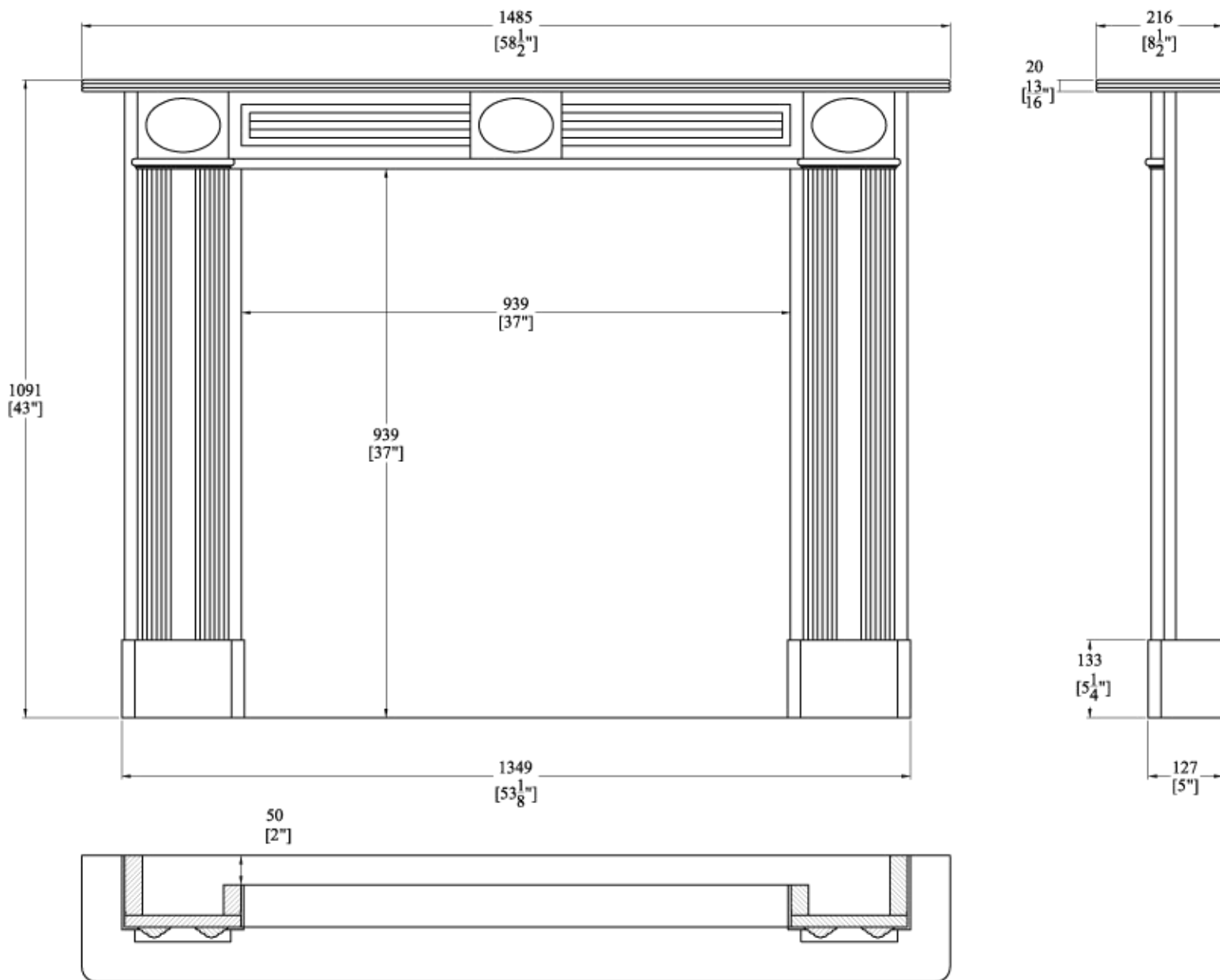



Cushion Mold Bullseye

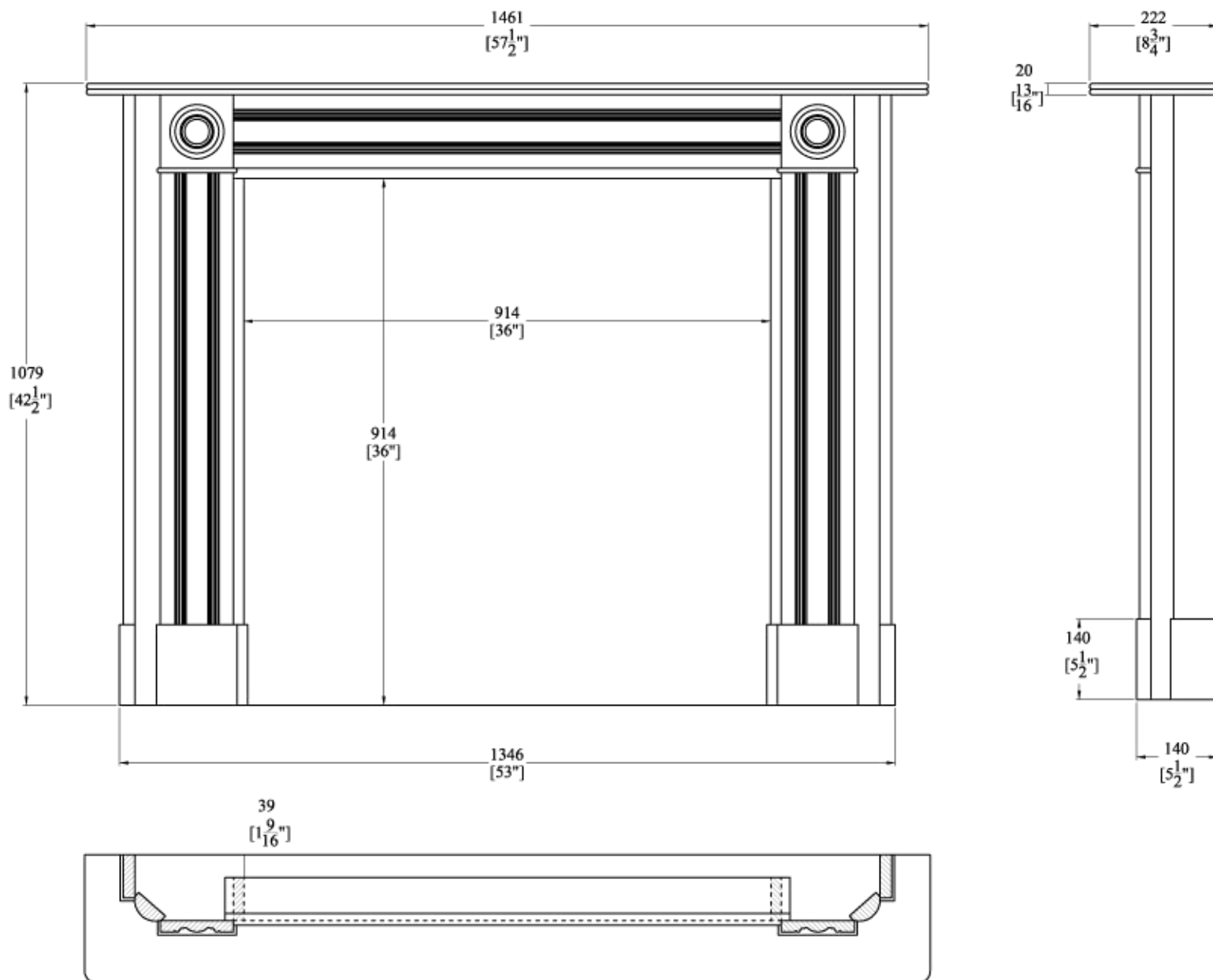



Reeded Bullseye

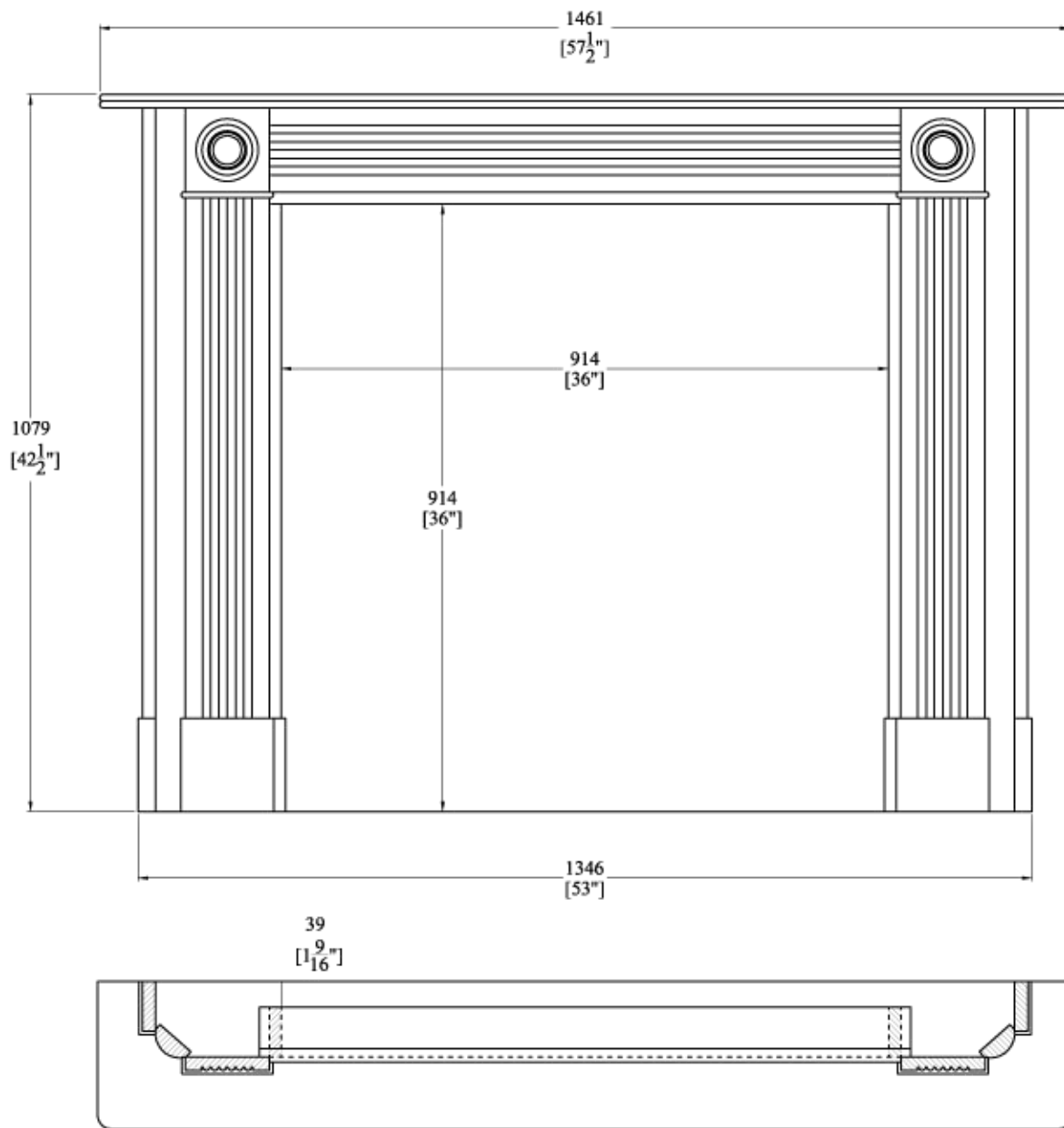



Regent

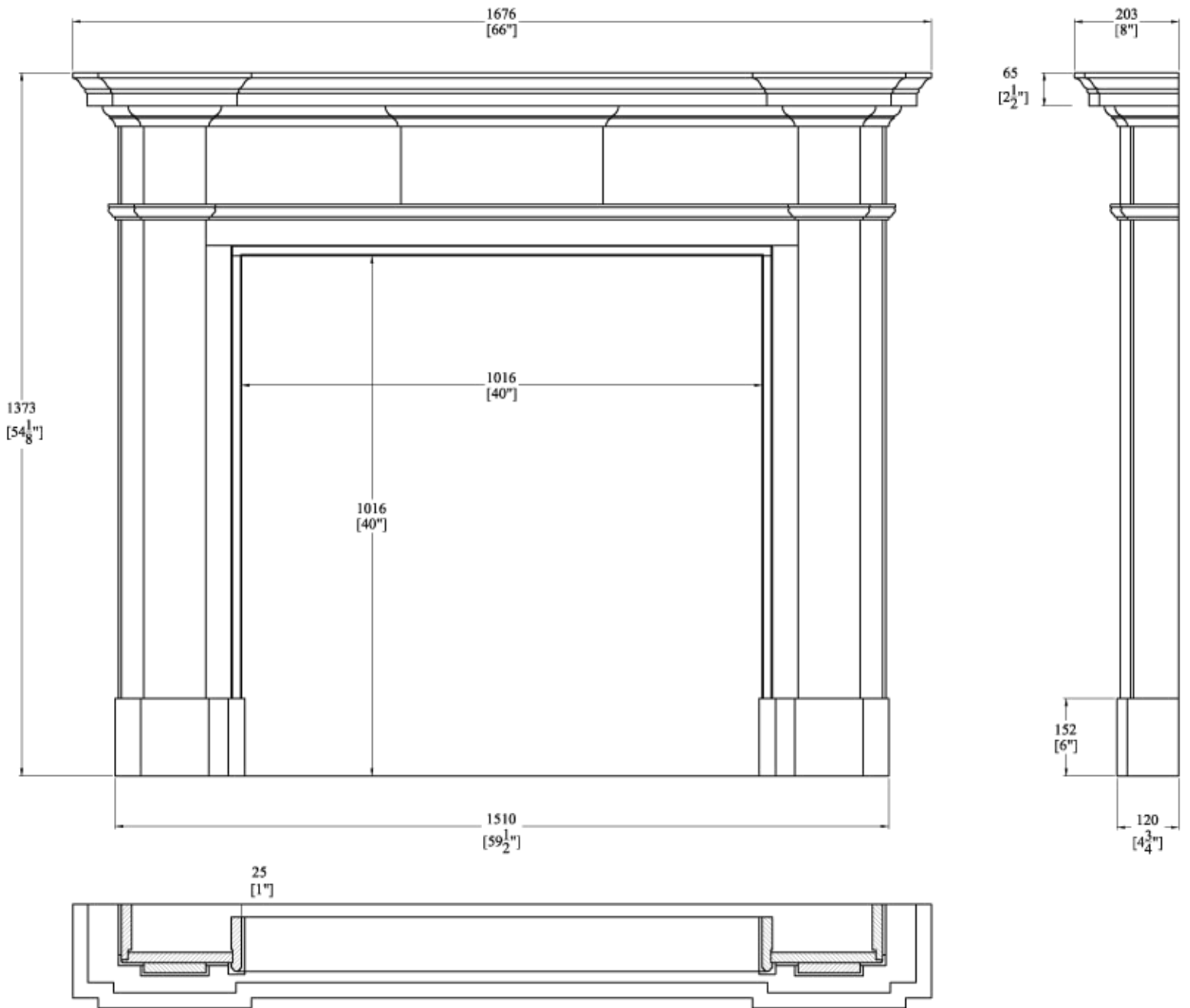



Ladbroke

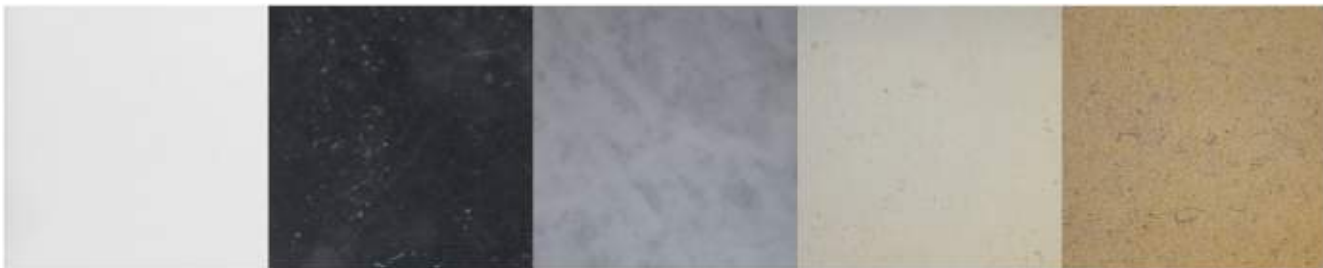
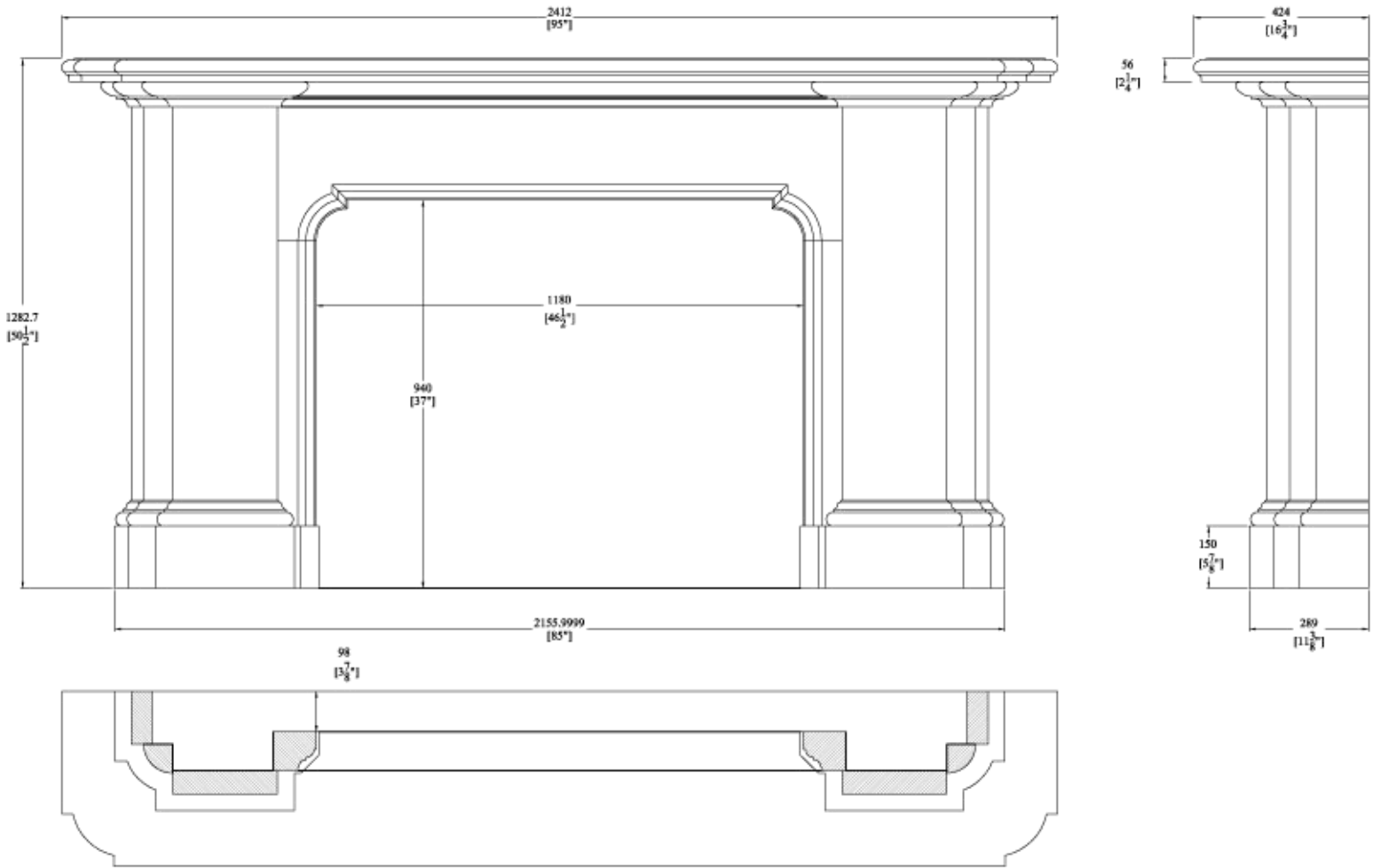



Penshurst

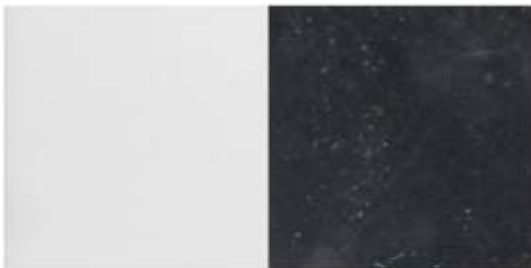
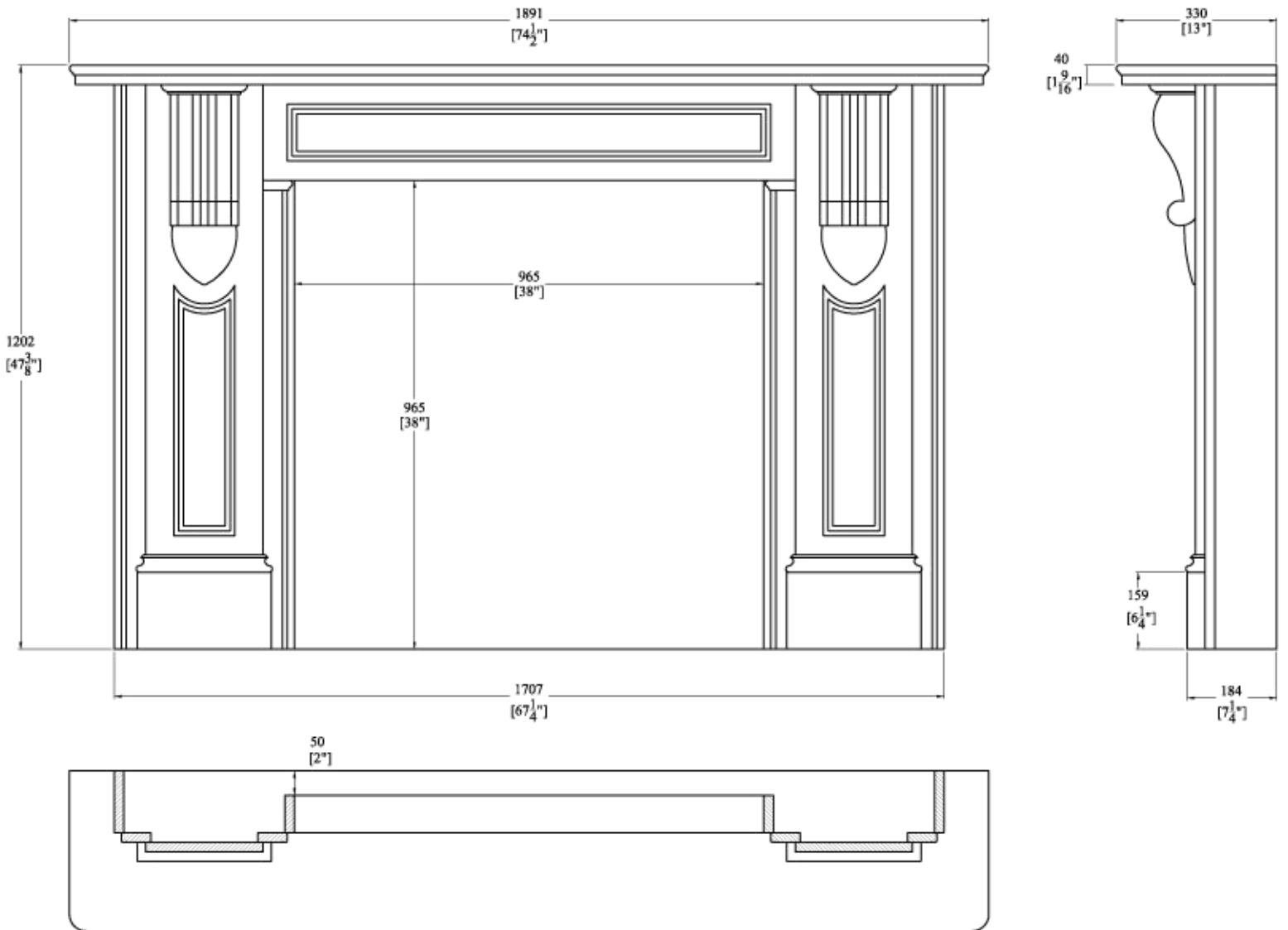



Clarendon

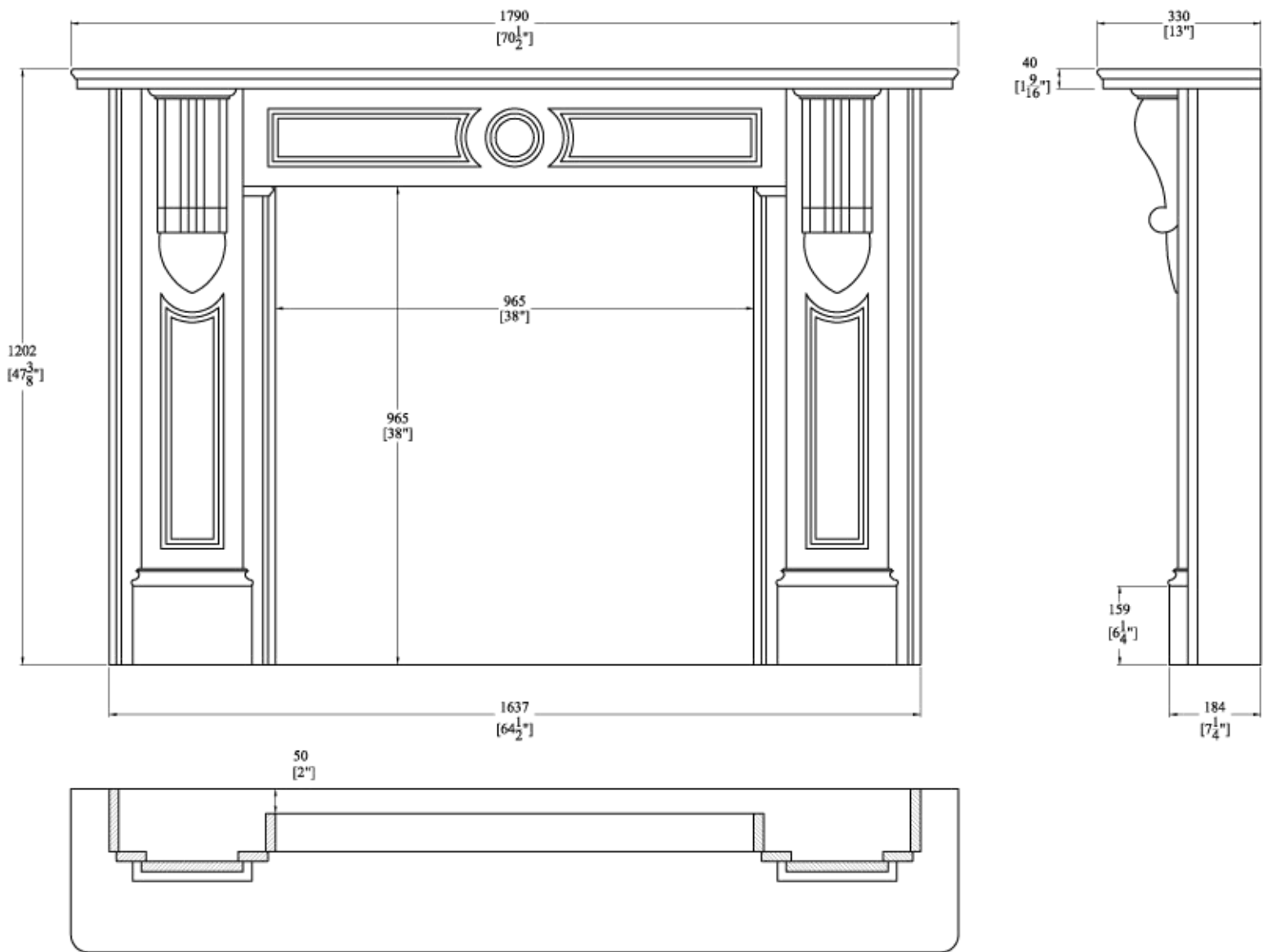



Elegant

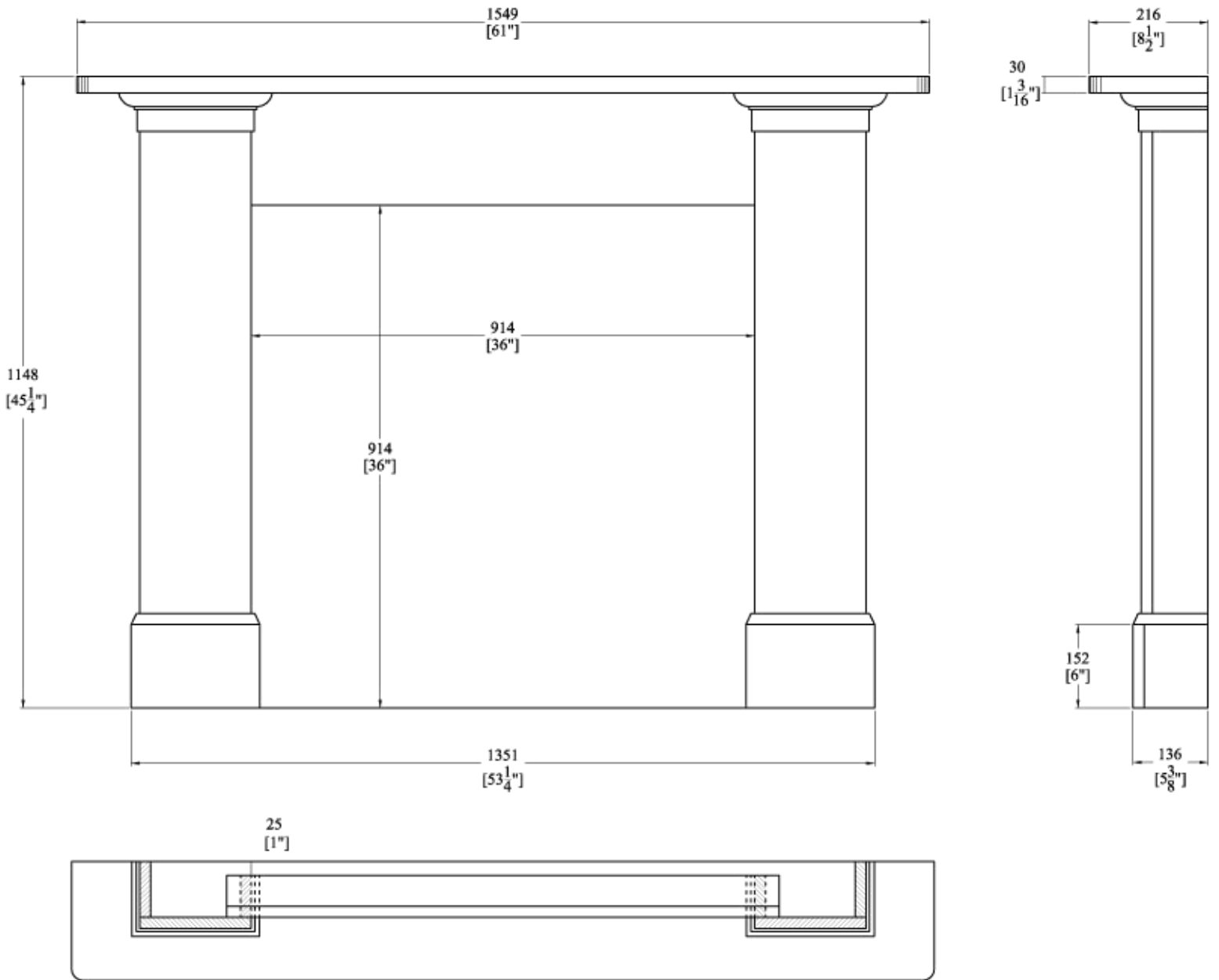



Longleat

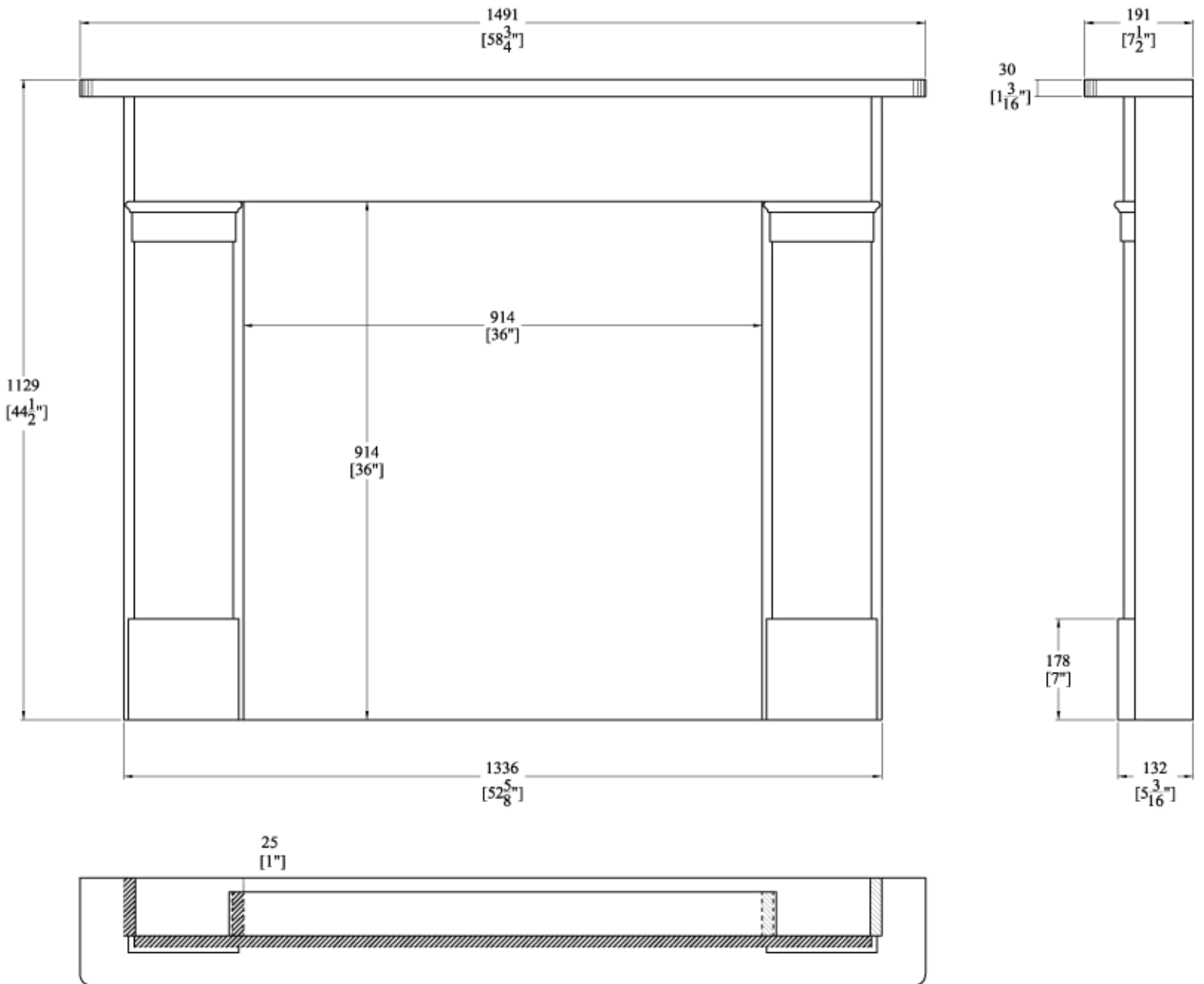



Victorian Classic

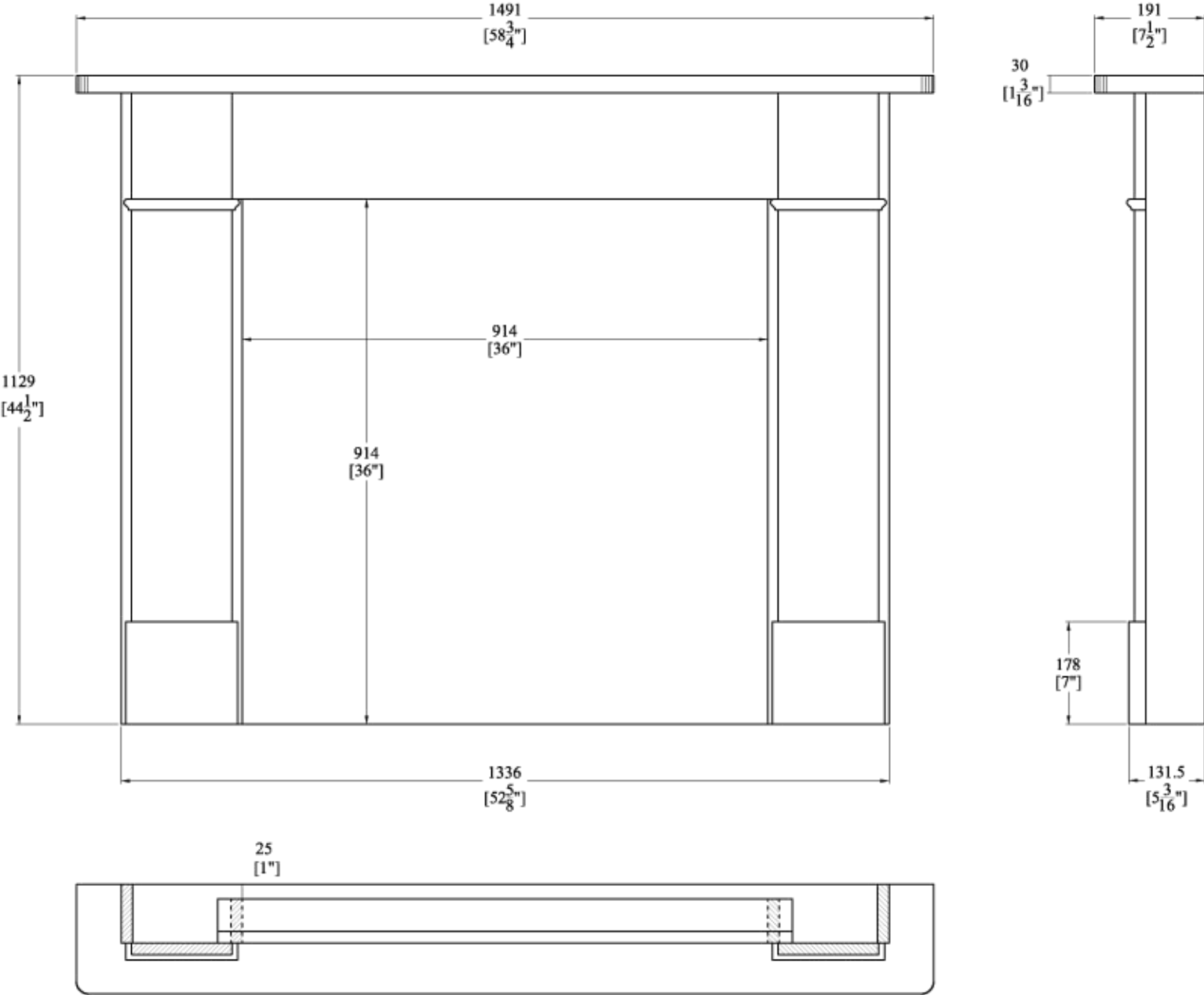



Albion 36

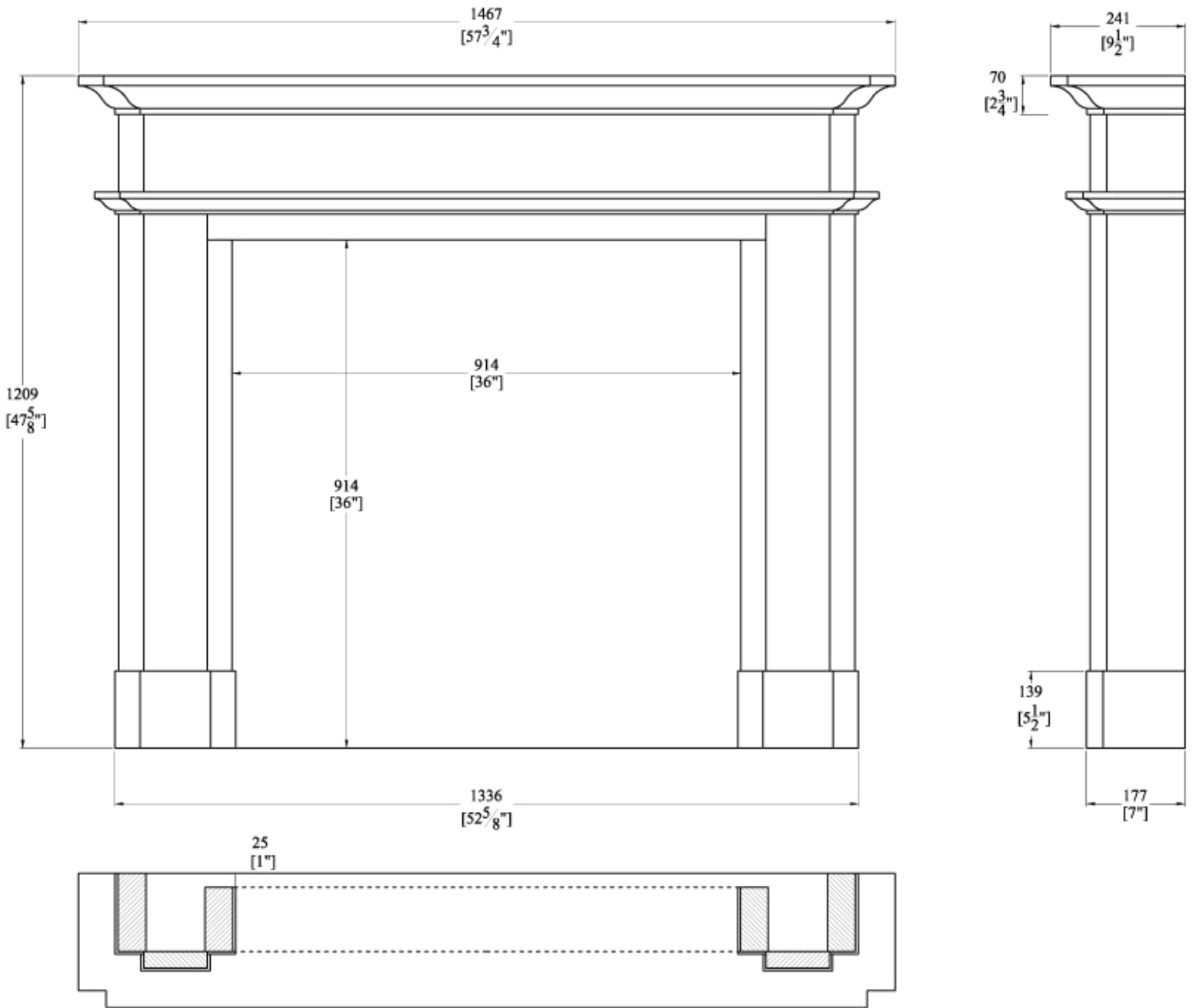



Arts & Crafts Small

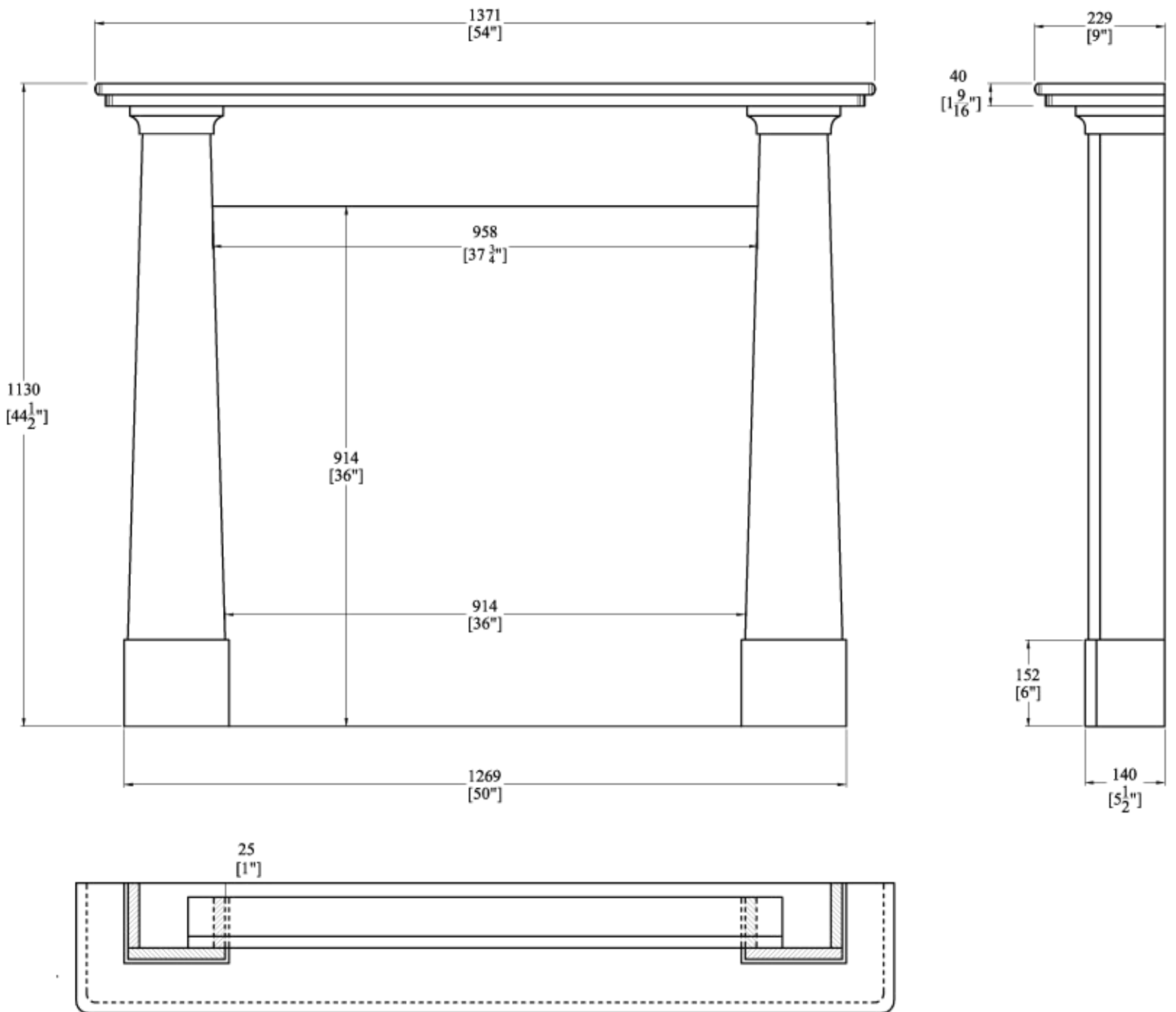



William Morris Small

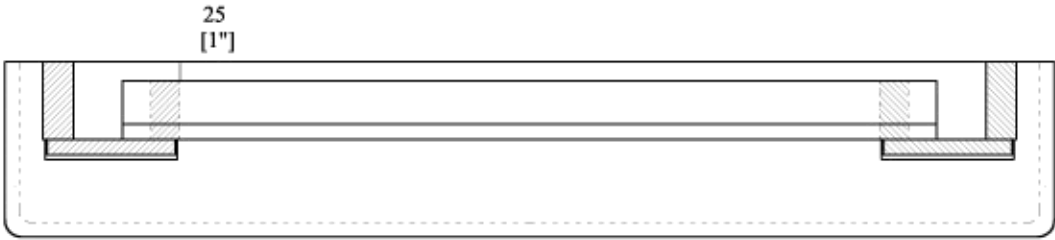
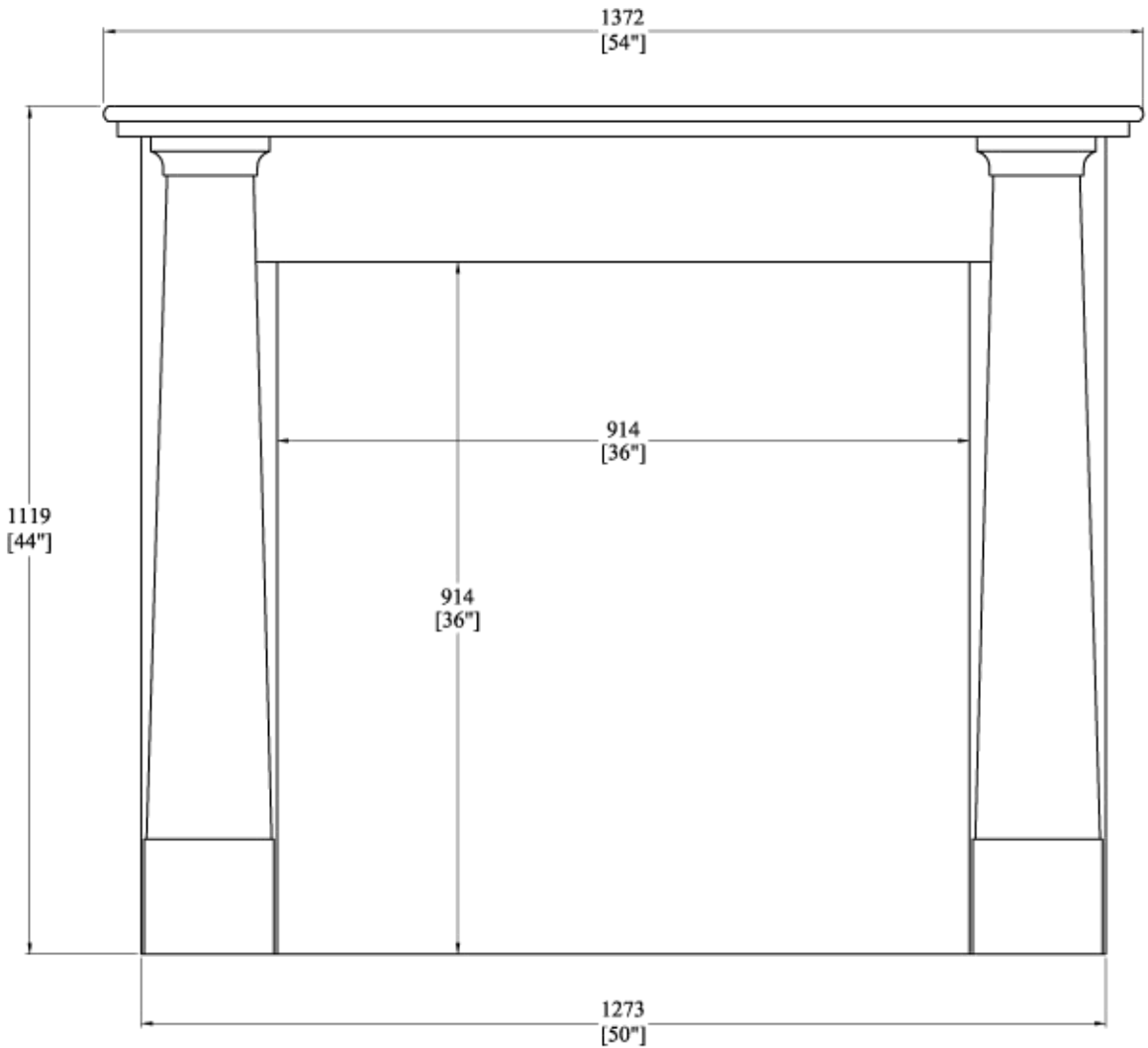



Bolection

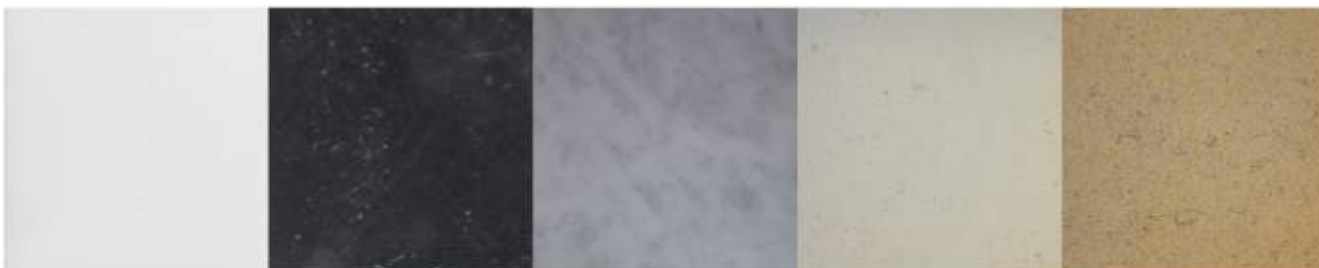
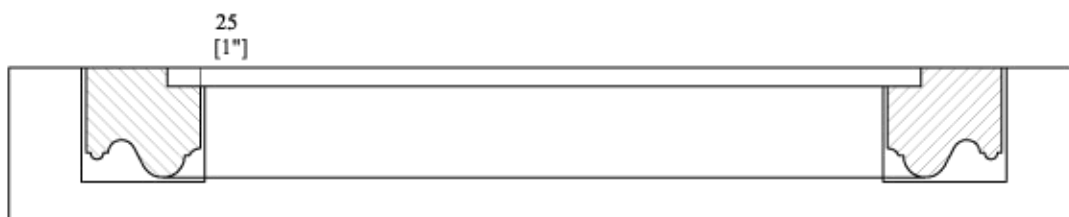
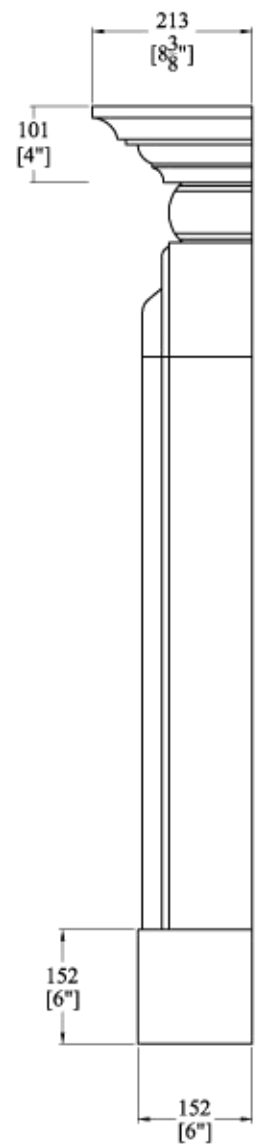
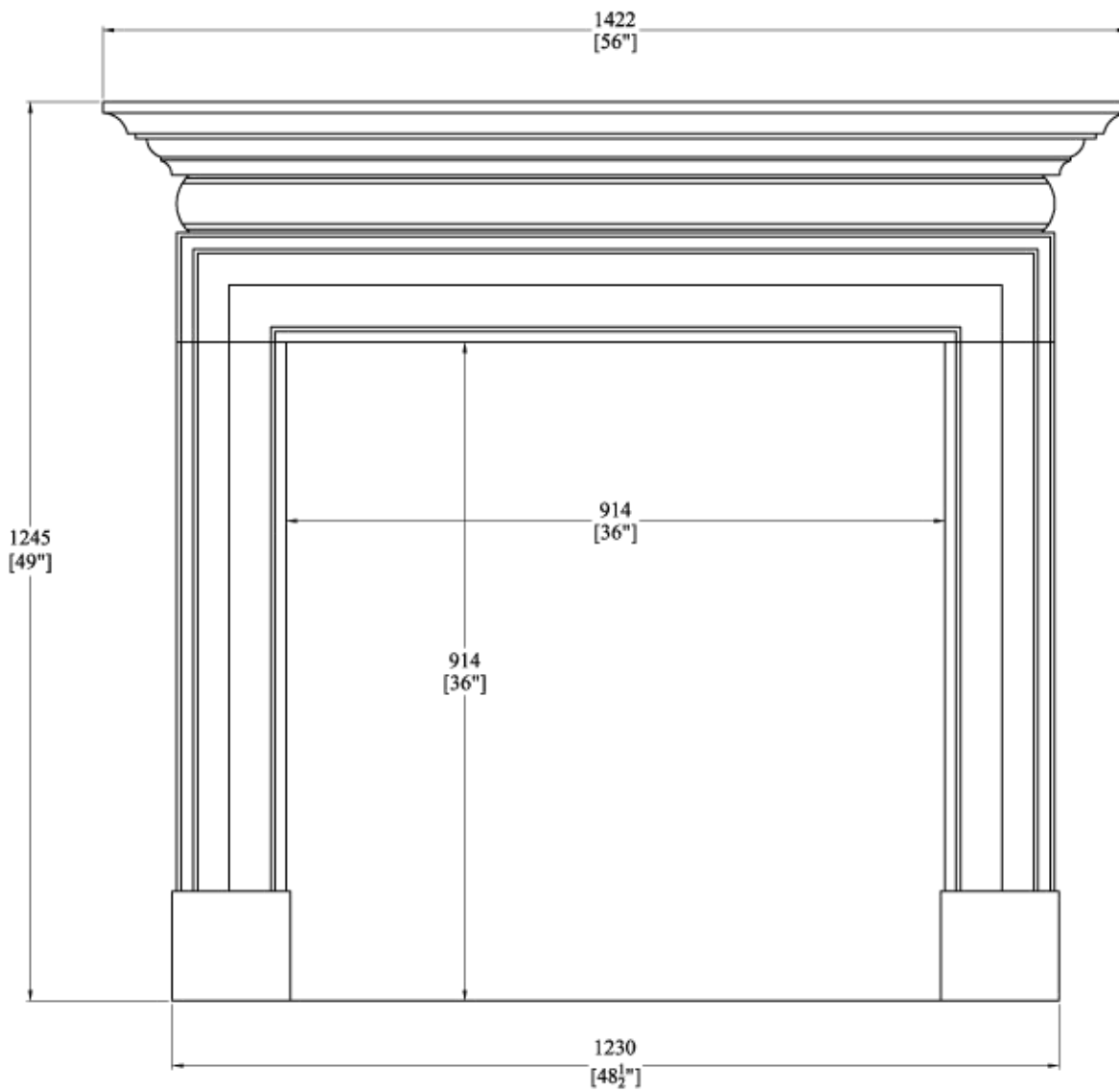



Camberley

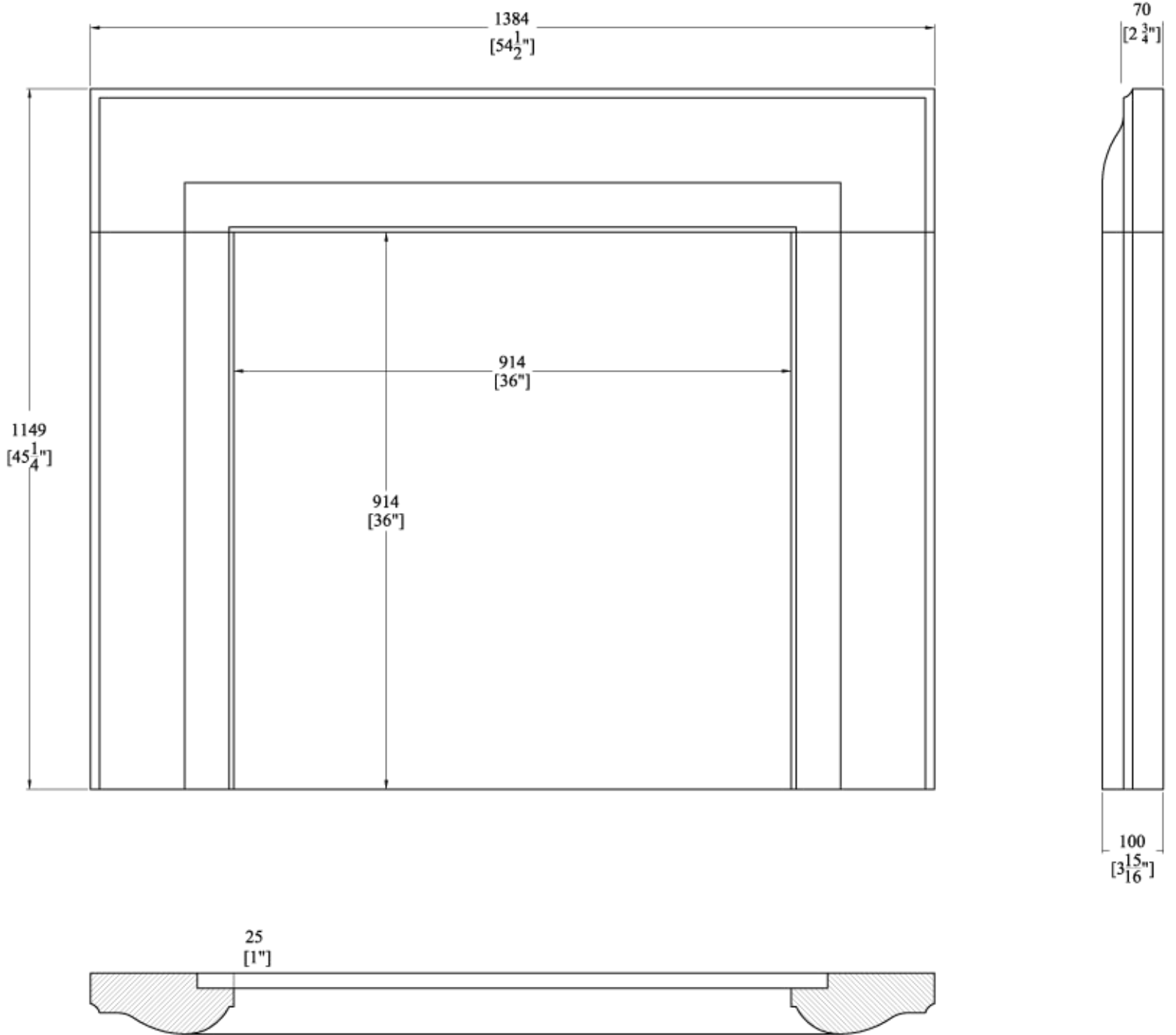



Cambridge Large

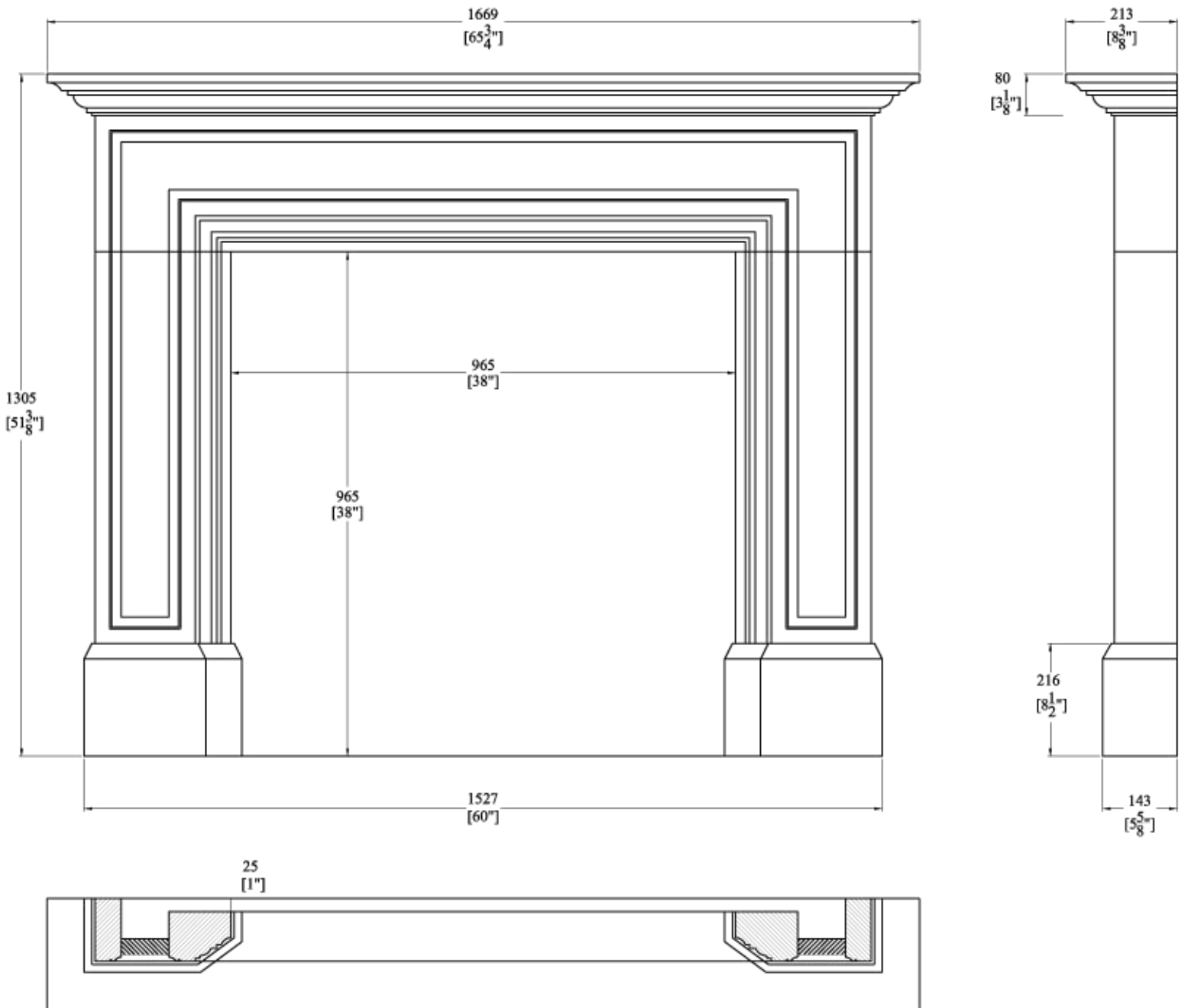



Chrysler 36

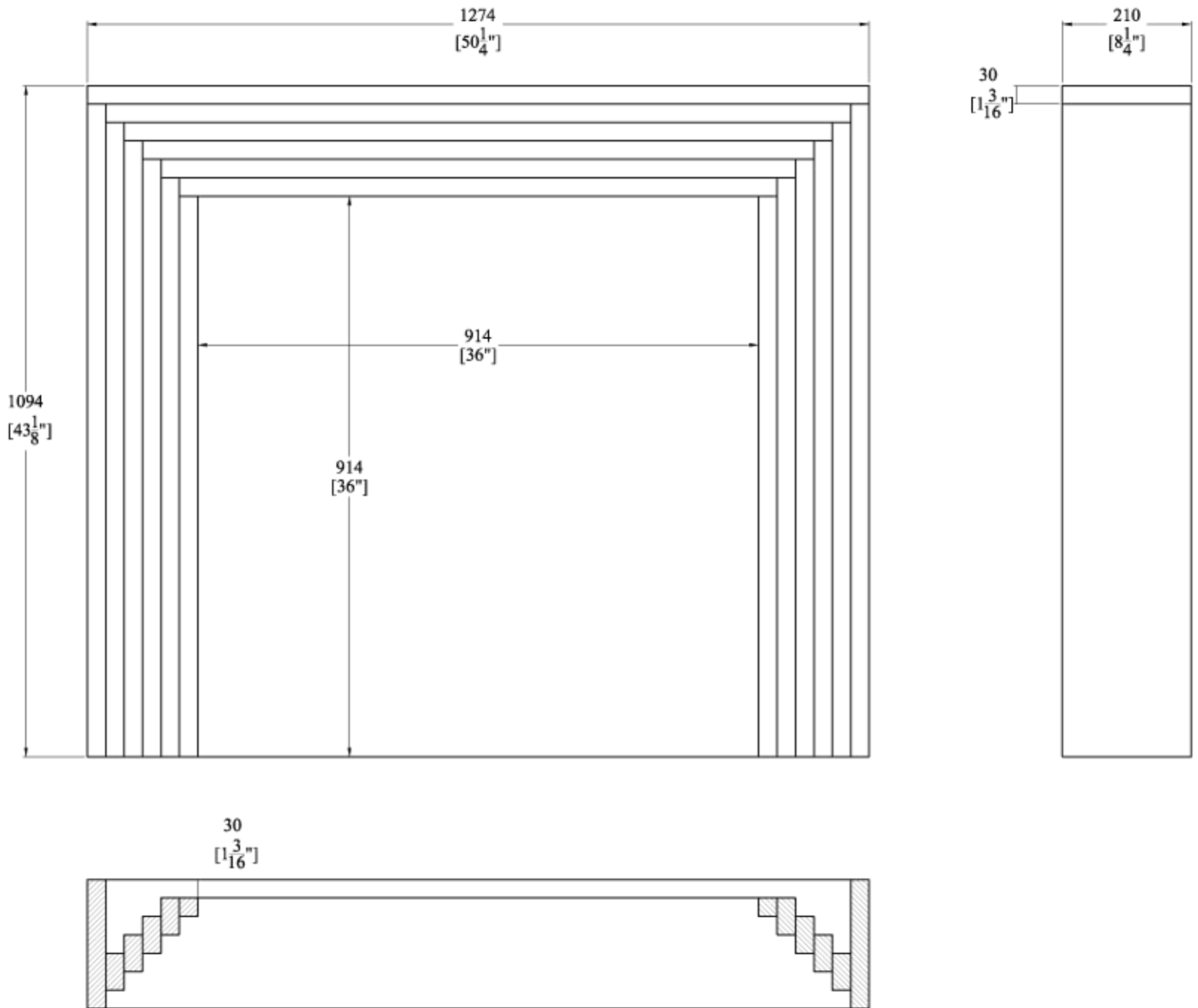



Claremont

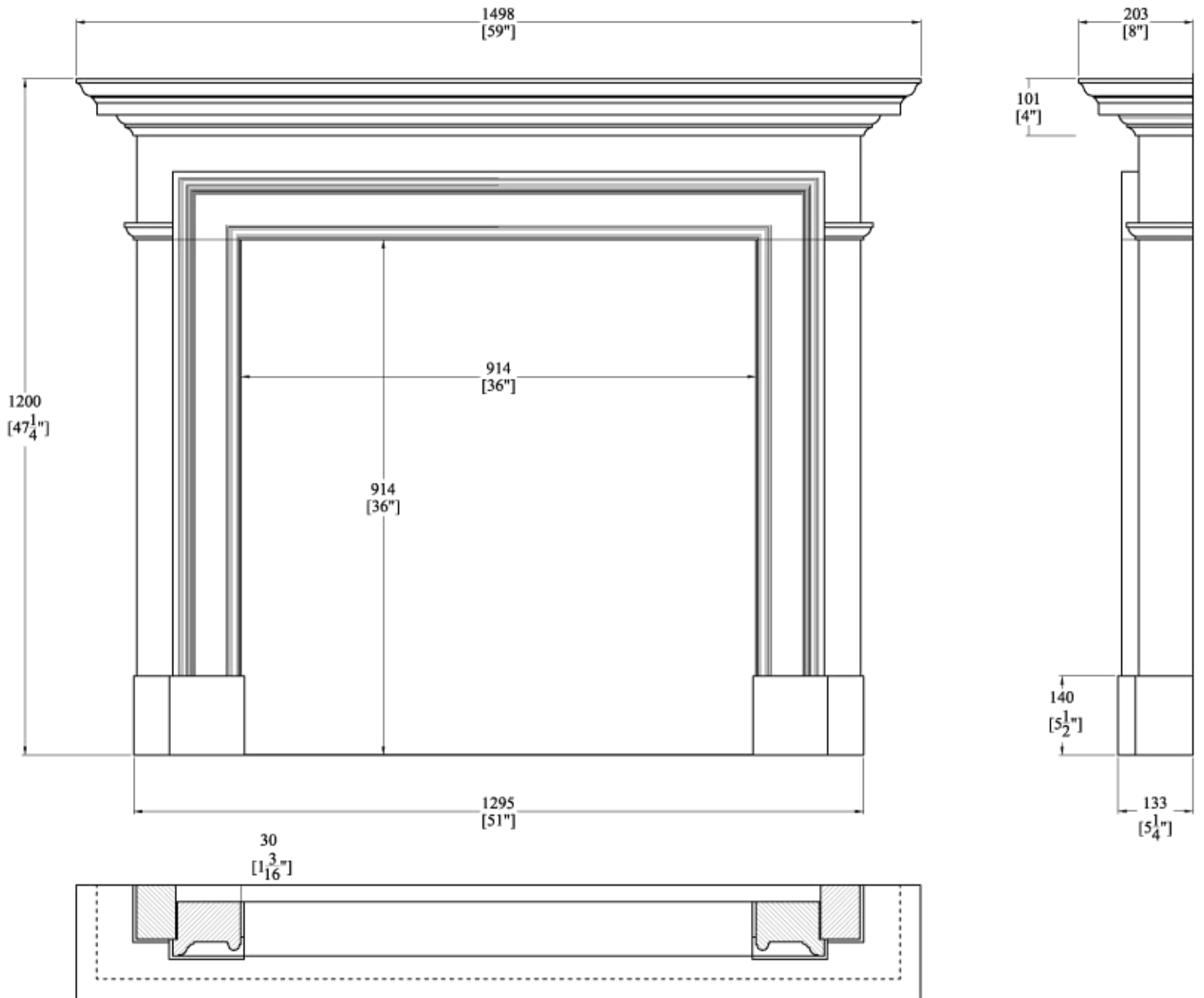



Marseille

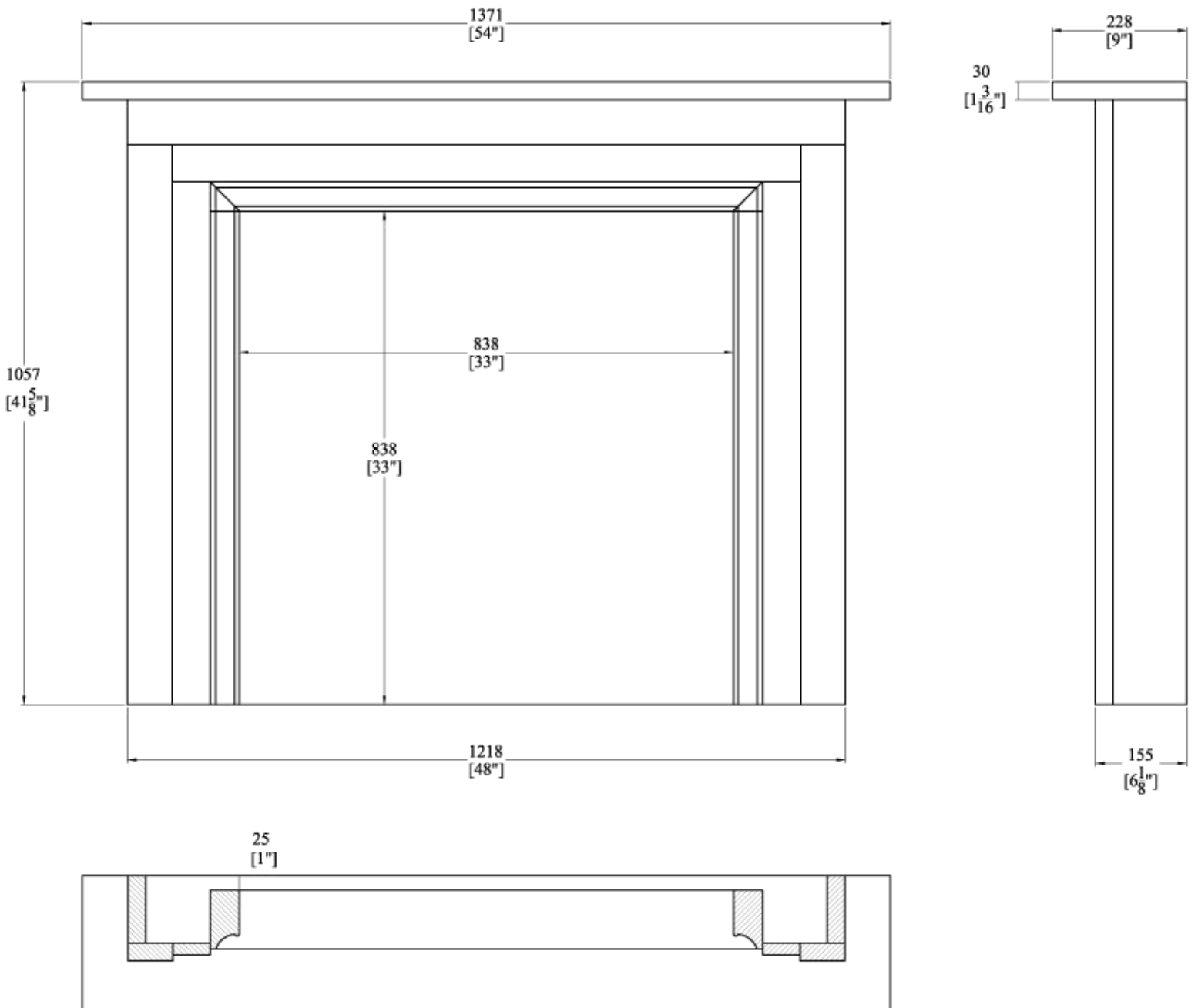



Metro

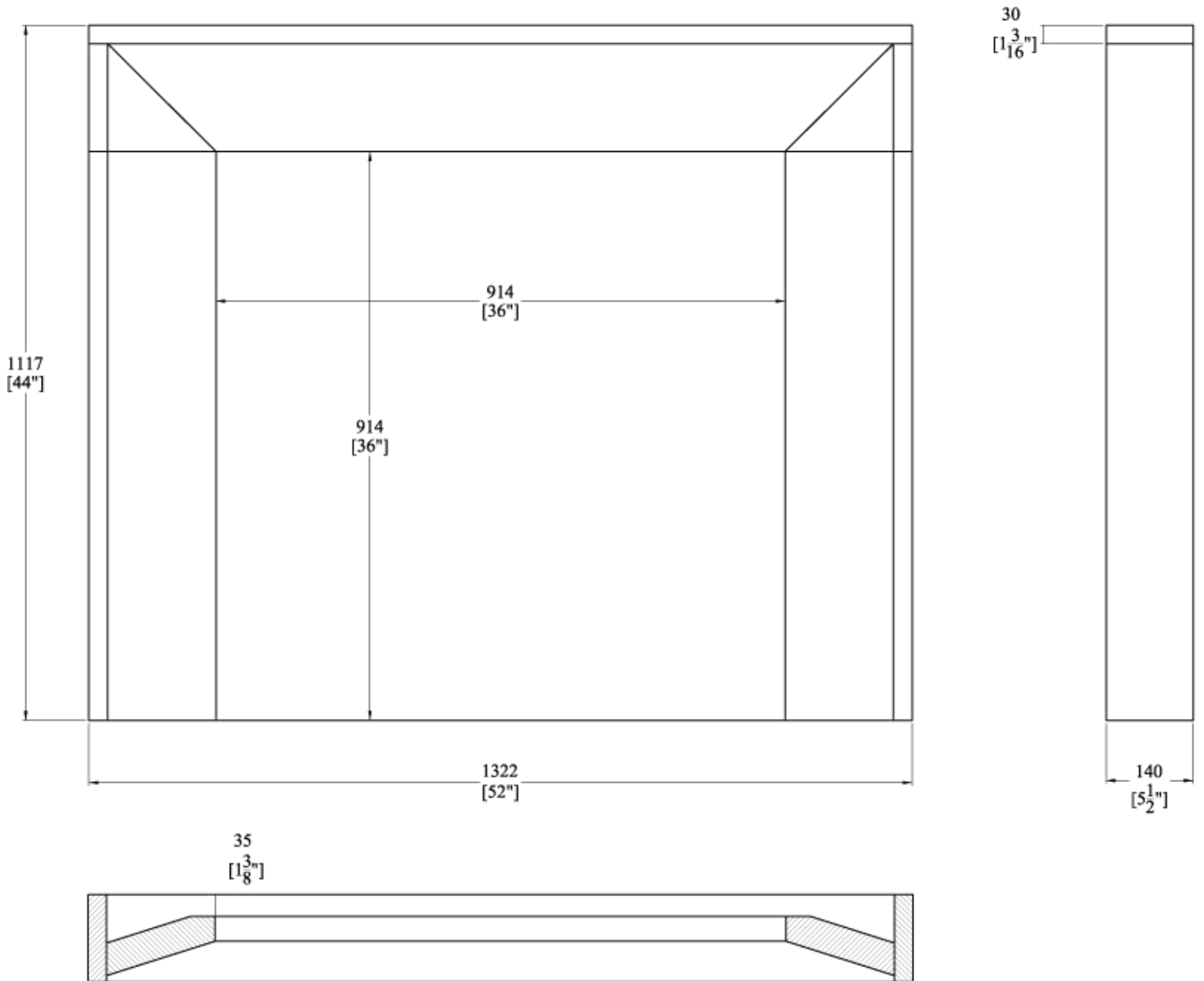



Saxburry

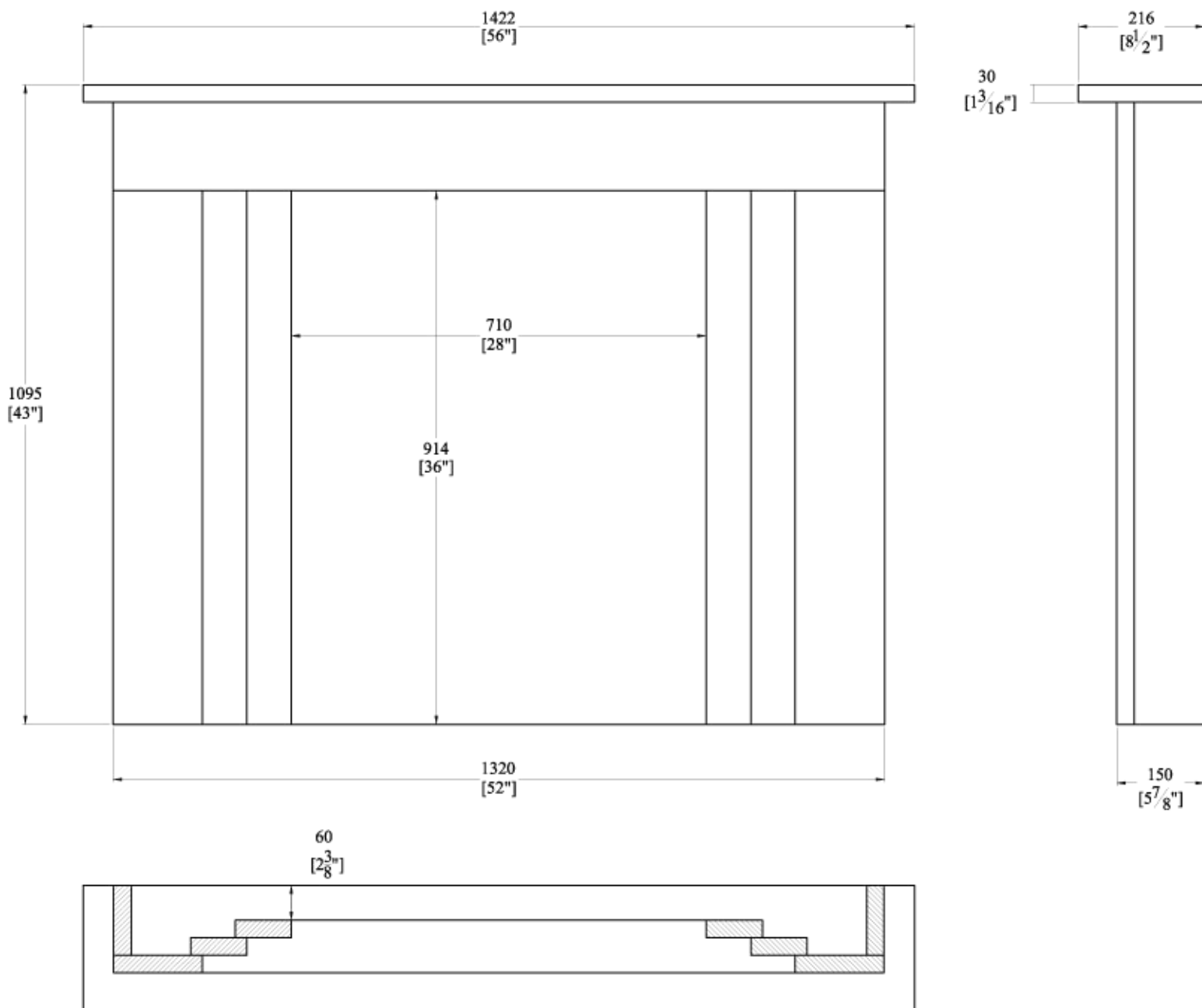



Simple

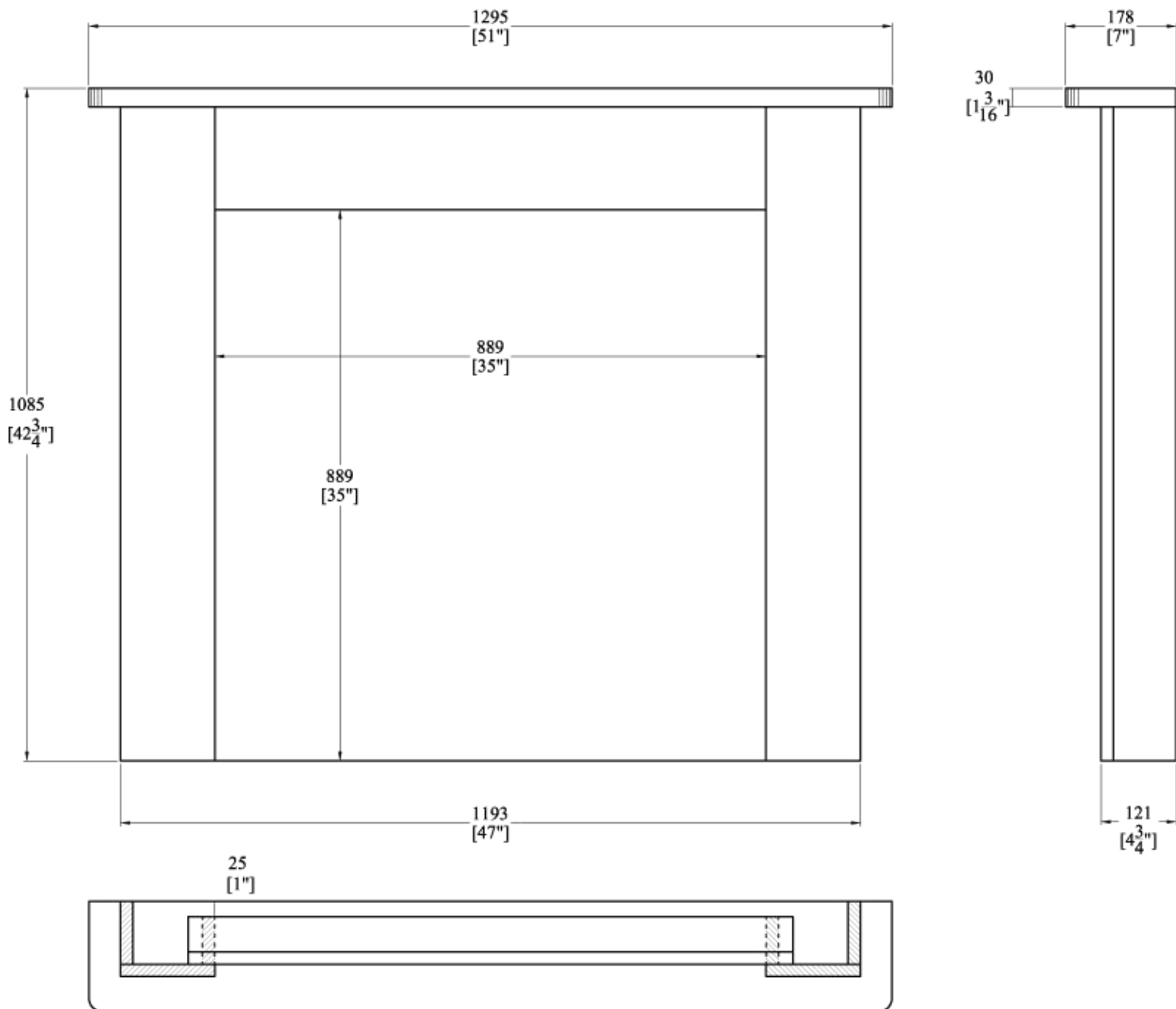



Stonehenge

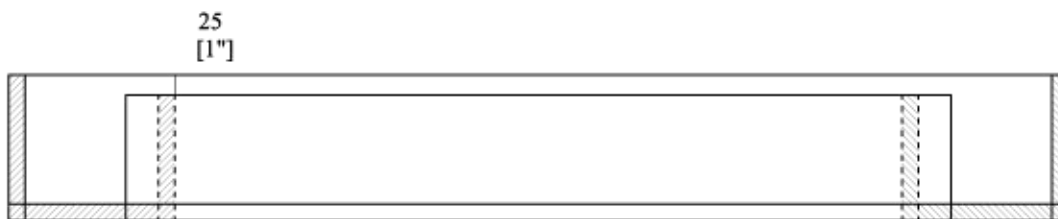
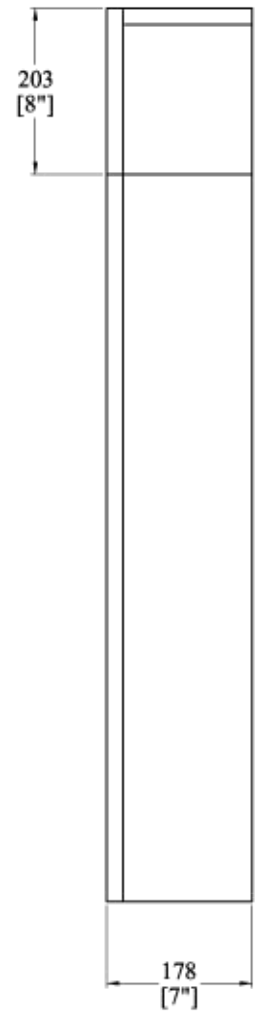
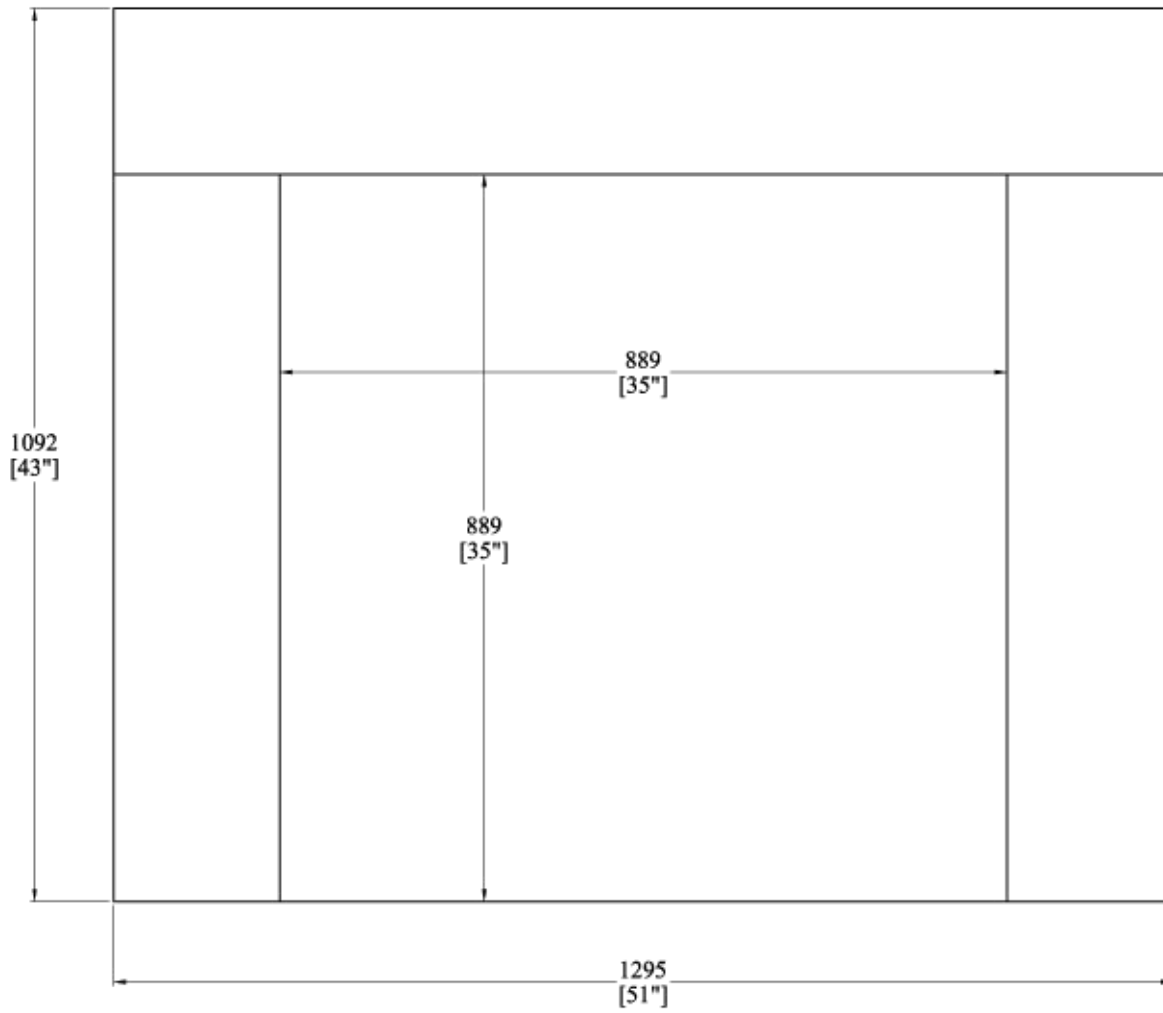



Arkley

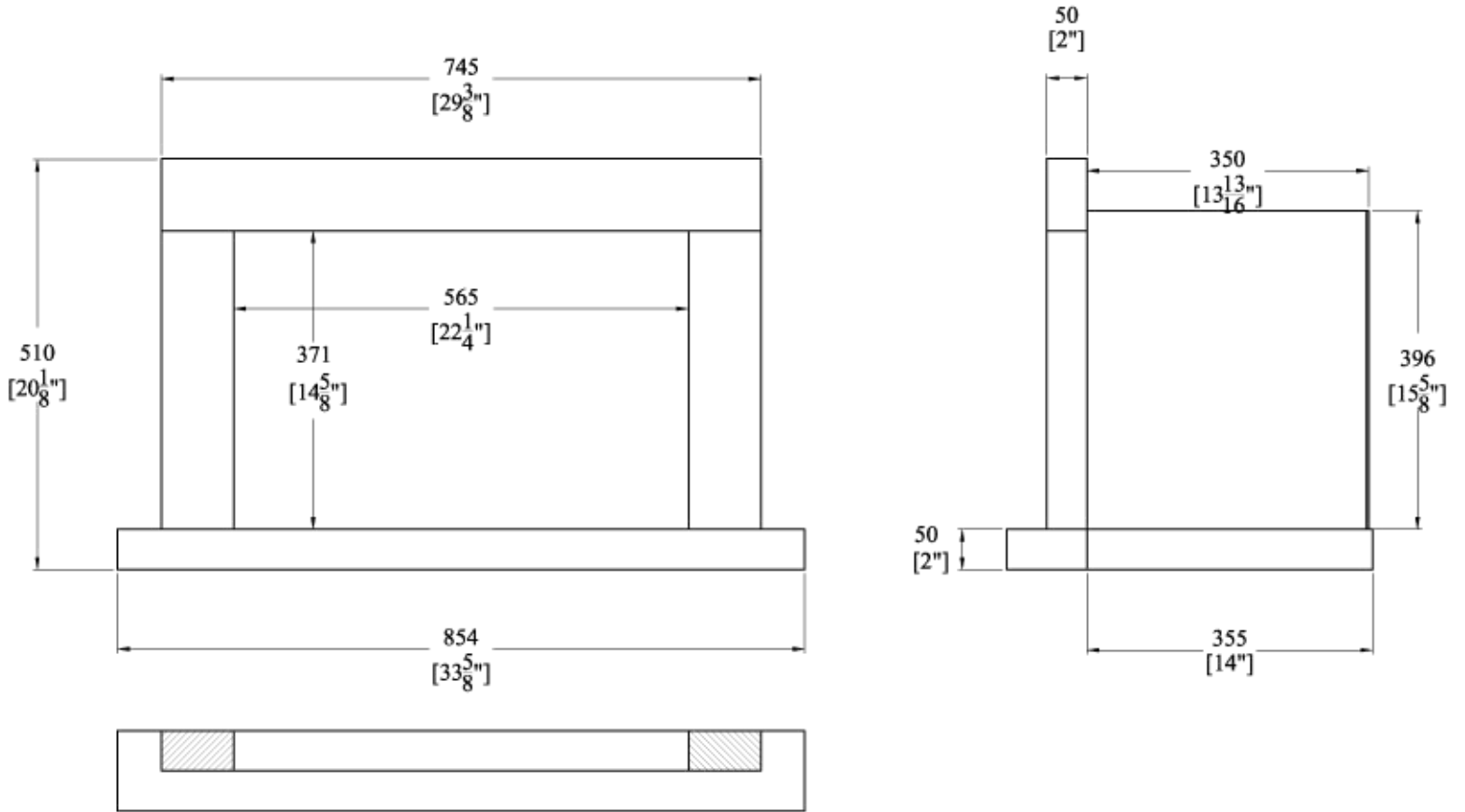



Classic

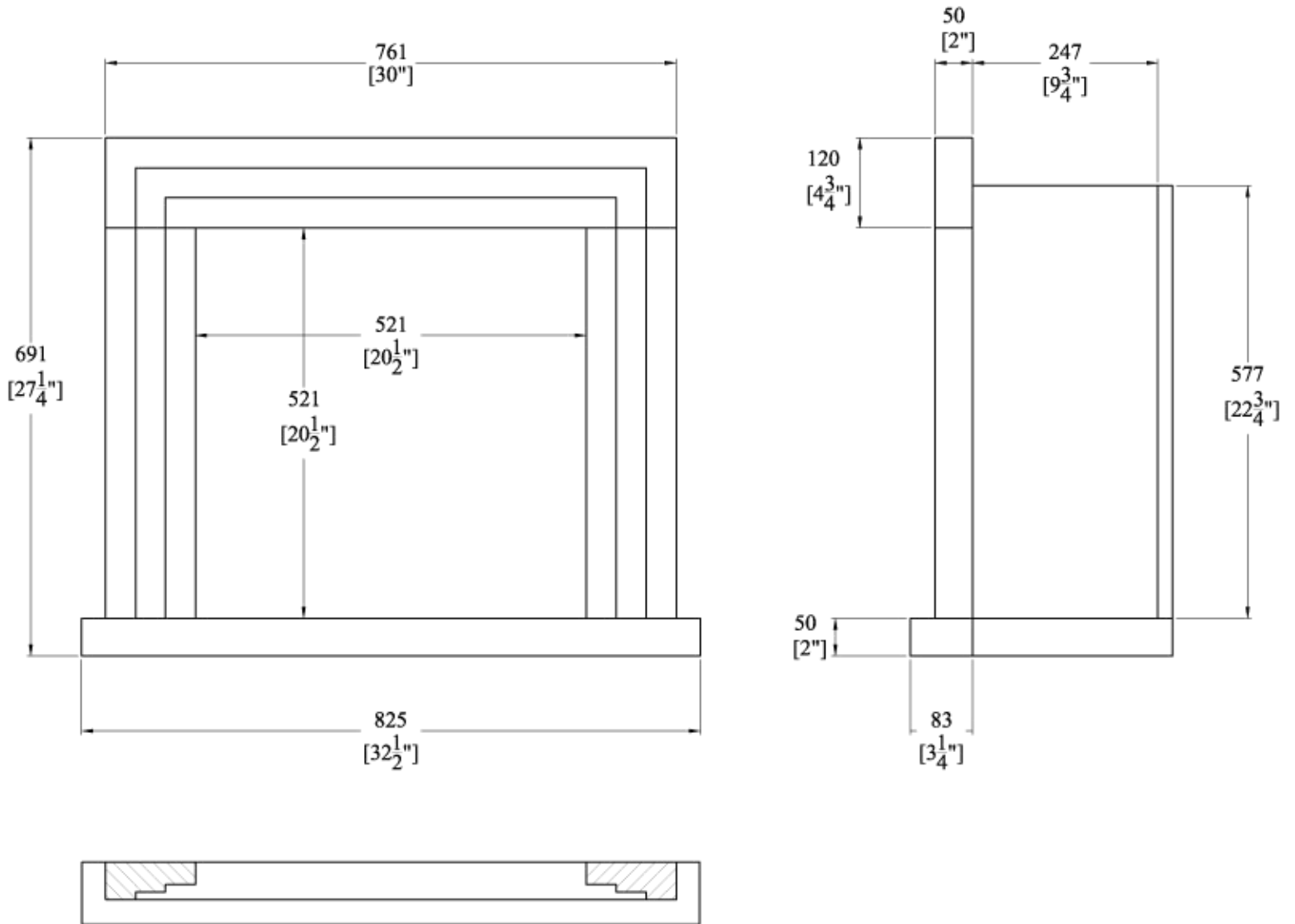



Eclipse

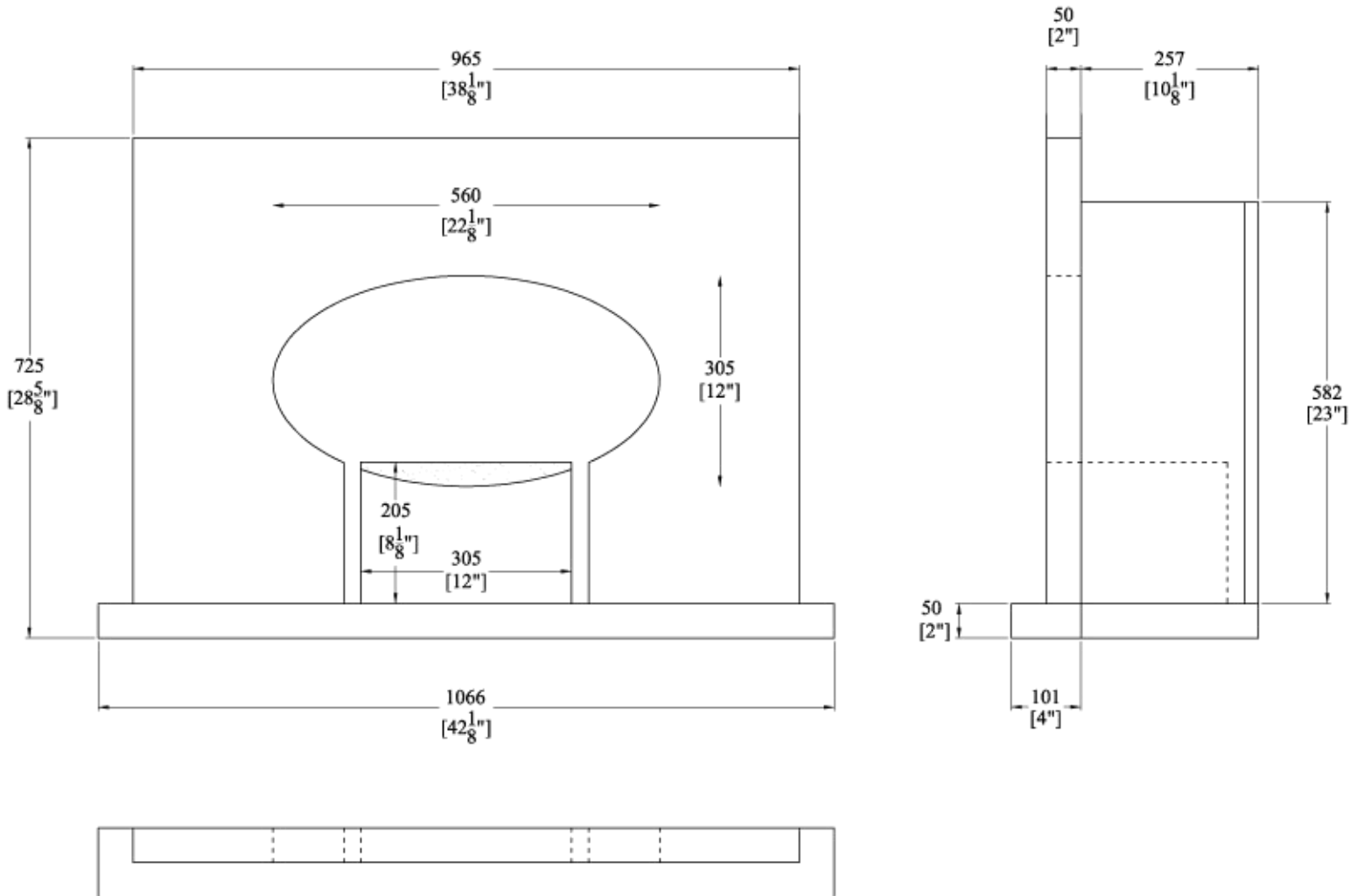



Lucca

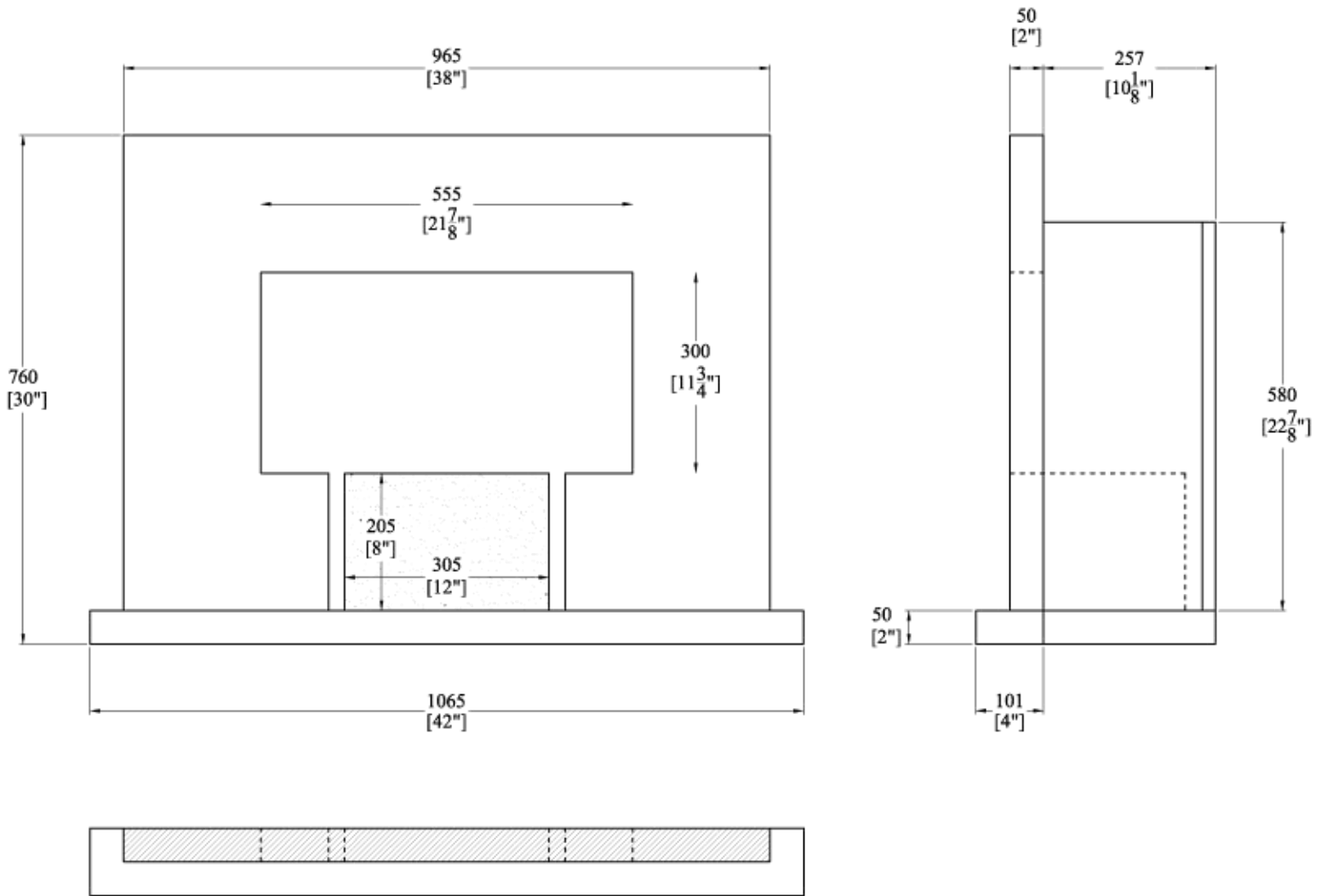



Sicily

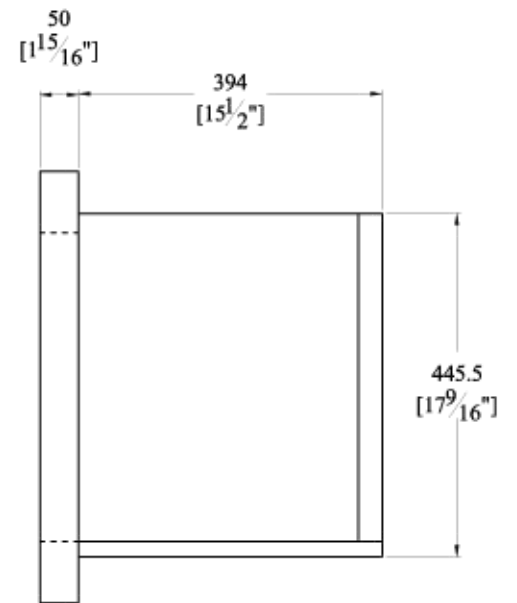
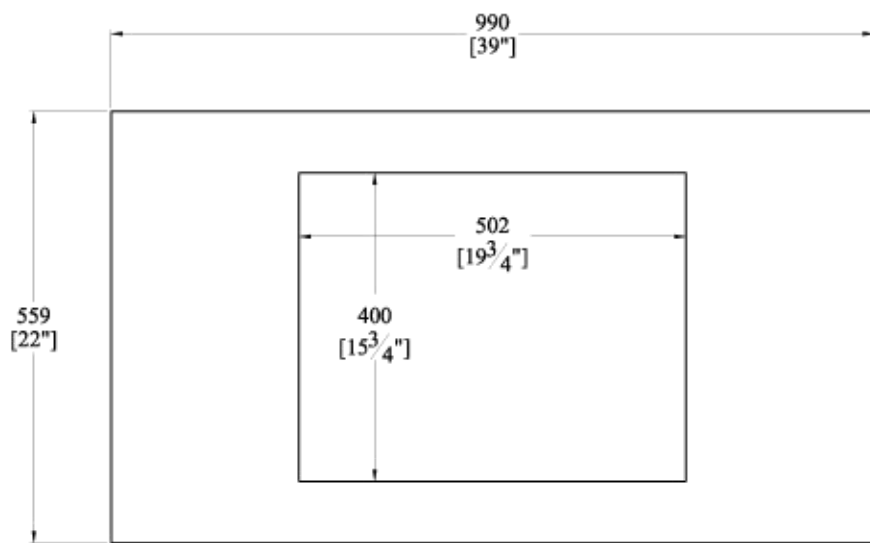

Guide to materials we use



White Marble

Our pure white marble is the result of metamorphism of a very pure (silicate-poor) limestone or dolomite protolith. Quarried in Northern Italy and Asia.

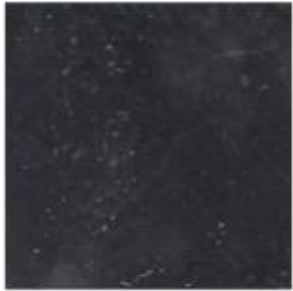

Black Marble

This unusually consistent black marble quarried in Asia was formed around 360 millions years ago by heat and pressure in the earth's crust.



White Carrara

Another white background marble with characteristic grey veins from Italian Carrara-Massa region. This marble is a rock resulting from metamorphism of limestone or dolomite rock. Metamorphism causes variable recrystallization of the original carbonate mineral grains.



Rosal Limestone

A creamy sedimentary rock with visible darker fossils. It is composed largely of the minerals calcite and aragonite. The primary source of the calcite in limestone is most commonly marine organisms. Our limestone is being quarried in Portugal.



Bathstone

It is an Oolitic limestone comprising granular fragments of calcium carbonate formed in the middle Jurassic period some 135 million years ago. This stone is a porous creamy and beige colour which mellows with age. Quarried in South West England.



Verde Ardesie

A beautiful fine-grained calcareous sandstone. The combination of lime, quartz grain and glauconite produces the unique green colour which is contrasted by occasional gray and dark green fossilization. Quarried in south Bavaria, Germany.

Guide to dimensions

